

# Stormy 335P

## Open Stand and Agitator Pump 50HZ

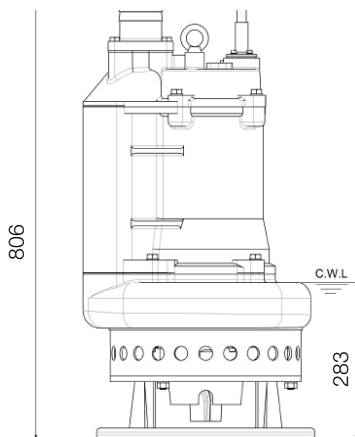
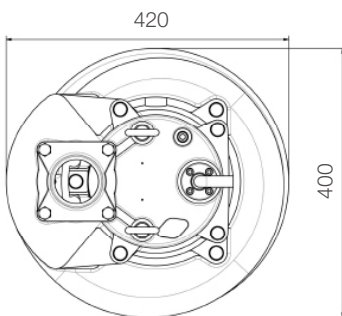

unit : mm

Weight : 123kg

### Pump specifications

OUTPUT	HEAD	FLOW
5.5kW	Rated : 14m, 46ft	Rated : 14.2 L/s, 224gpm
7.5HP	Max : 21m, 69ft	Max : 28.3 L/s, 449gpm
<b>SHAFT SPEED</b>		1450rpm
<b>OUTLET</b>		80mm, 3in
<b>SOLID PASSAGE</b>		25mm, 1in

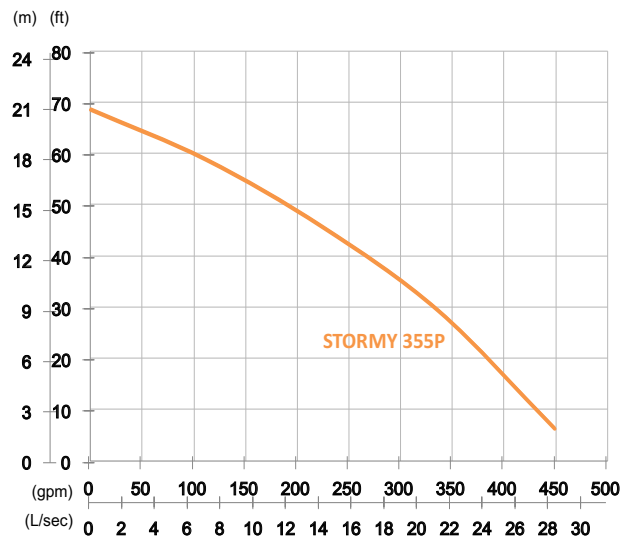

### Features

#### Pump Type

Electric Submersible Pumps  
 3-Phase

#### Motor

Type: Induction Motor  
 Poles: 4 Pole  
 Insulation: Class F  
 Protector: Circle Thermal Protector  
 Starter: D.O.L.

#### Lubricant

Food Grade (ISO VG32)

#### Impeller Type

Opened

#### Shaft Seal

Double Mechanical Seal  
 Silicon Carbide VS Ceramic / Carbon

#### Bearings

C3 Shielded ball bearings

#### Cable

PVC (CSA Certified) / H07BQ-F  
 10m or longer upon request

#### Materials

Pump Casing: Ductile Iron  
 Impeller: Chromium Iron  
 Motor Frame: Gray Iron  
 Motor Shaft: Stainless Steel  
 Wear Plate: Chromium Iron  
 Agitator: Chromium Iron

#### Max. Liquid Temperature

40°C

#### Max. Submersion Depth

20m

#### pH Range

pH 5 - pH 8