

Stormy 8220P

Open Stand and Agitator Pump 50HZ

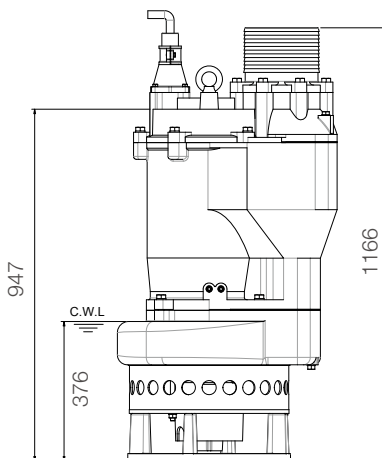
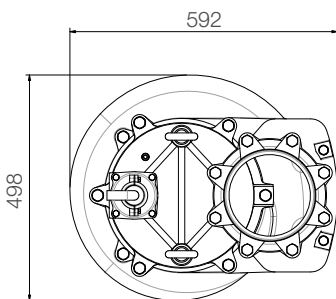

unit : mm
 Weight : 355kg

Pump specifications

OUTPUT	HEAD	FLOW
22kW	Rated : 18m, 59ft	Rated :63.3 L/s, 1003 gpm
30HP	Max :24m, 79ft	Rated :108.3 L/s, 1716 gpm
SHAFT SPEED		1450rpm
OUTLET		200mm, 8in
SOLID PASSAGE		35mm, 1.2in

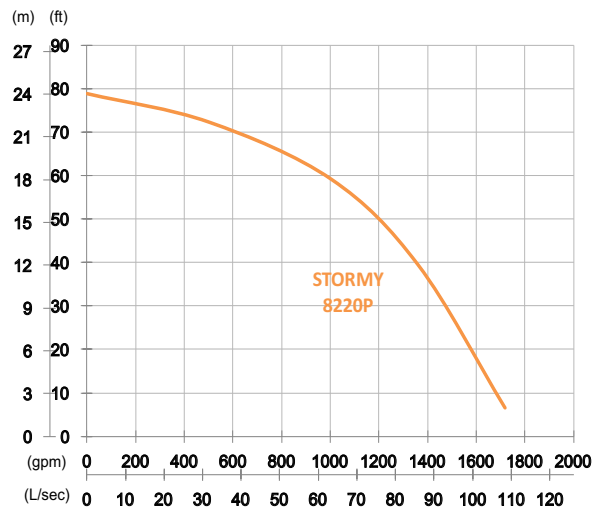

Features

Pump Type

Electric Submersible Pumps
 3-Phase

Motor

Type: Induction Motor
 Poles: 4 Pole
 Insulation: Class F
 Protector: Circle Thermal Protector
 Starter: D.O.L.

Lubricant

Food Grade (ISO VG32)

Impeller Type

Opened

Shaft Seal

Double Mechanical Seal
 Silicon Carbide VS Ceramic / Carbon

Bearings

C3 Shielded ball bearings

Cable

PVC (CSA Certified) / H07BQ-F
 10m or longer upon request

Materials

Pump Casing: Ductile Iron
 Impeller: Chromium Iron
 Motor Frame: Gray Iron
 Motor Shaft: Stainless Steel
 Wear Plate: Chromium Iron
 Agitator: Chromium Iron

Max. Liquid Temperature

40°C

Max. Submersion Depth

20m

pH Range

pH 5 - pH 8