

Titan 355

Heavy Duty Dewatering Pump 50HZ



Pump specifications

OUTPUT	HEAD	FLOW
5.5kW	Rated : 14m	Rated : 14.2L/s
7.5HP	Max : 21m	Max : 28.3L/s
SHAFT SPEED		1450rpm
OUTLET		80mm
SOLID PASSAGE		25mm

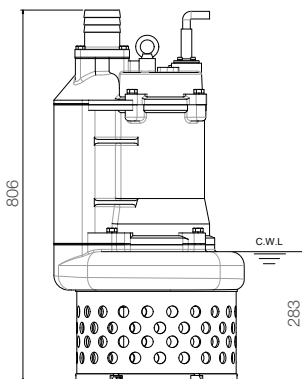
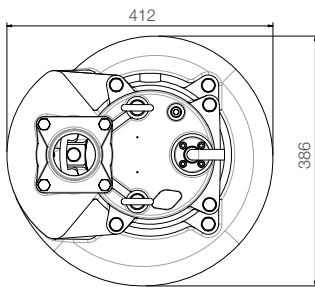
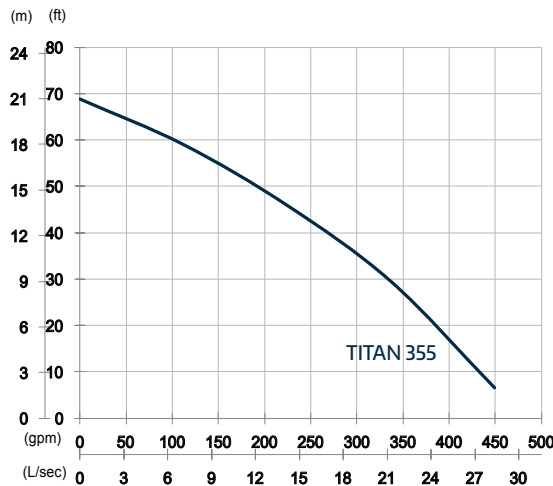

unit : mm

Weight : 128kg

Features

Pump Type

Electric Submersible Pumps
 3-Phase

Motor

Type: Induction Motor
 Poles: 4 Pole
 Insulation: Class F
 Protector: Circle Thermal Protector
 Starter: D.O.L.

Lubricant

Food Grade (ISO VG32)

Impeller Type

Opened

Shaft Seal

Double Mechanical Seal
 Silicon Carbide VS Ceramic / Carbon

Bearings

C3 Shielded ball bearings

Cable

PVC (CSA Certified) / H07BQ-F
 10m or longer upon request

Materials

Pump Casing: Ductile Iron
 Impeller: Chromium Iron
 Motor Frame: Gray Iron
 Motor Shaft: Stainless Steel
 Strainer: Carbon Steel

Max. Liquid Temperature

40°C

Max. Submersion Depth

20m

pH Range

pH 5 - pH 8