

SLURRY PUMPS

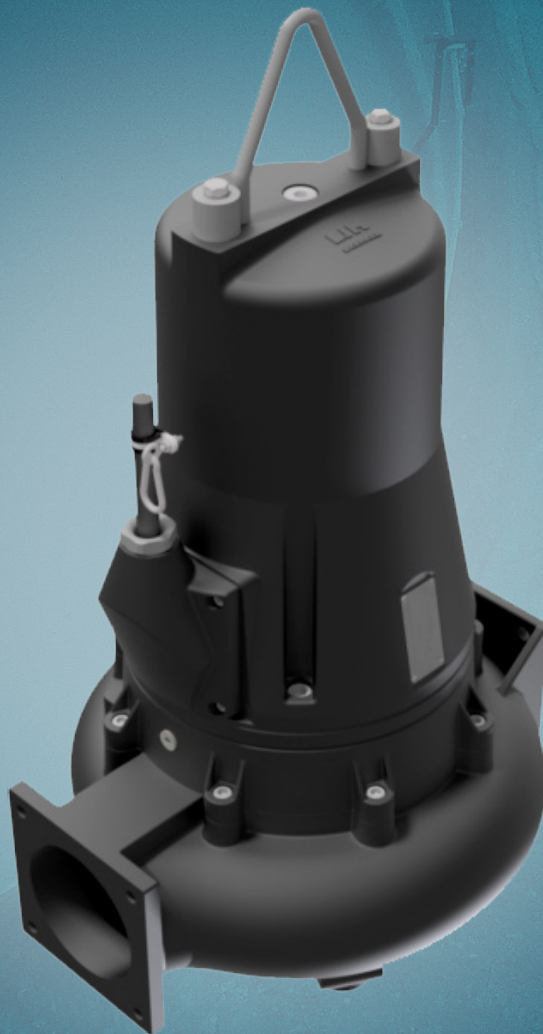

A solution for your **needs** and **requirements**
for an **efficient pumping process**

LJM
Lind Jensen

01.

WE DELIVER **SUBMERSIBLE PUMPS** OF **HIGH QUALITY**

All LJM submersible pumps can be delivered on a fixed bracket or with a simple coupling system.

With LJM's slurry pump models, you get the solution for your needs and requirements for an efficient pumping process. We deliver submersible pumps of high quality in many sizes from 1.5 kW to 18.5 kW.

This applies to all Lind Jensen submersible slurry pumps

- ✓ Built-in cutting system for the fine shredding of straw and feed residues
- ✓ Quality pumps with proven long-lasting durability
- ✓ Wide range of mounting brackets for all tank types
- ✓ Can be mounted with a fixed foot or slide bracket as needed



**We deliver
submersible pumps
of high quality in
many sizes**



| Model | kW | Max. capacity m3/h | Max. head | Outlet dimension | Weight kg. |
|-----------|---------|-----------------------|-----------|---------------------|------------|
| DPAS S090 | 1,5 kW | 100 | 6 | 2,5" | 57 |
| DPAE S100 | 3,0 kW | 106 | 8,9 | 4" | 91 |
| DPFH S132 | 5,5 kW | 252 | 10,1 | 4" / 6" | 162 |
| DPFH S132 | 7,5 kW | 265 | 14,5 | 4" / 6" | 165 |
| DPFH R160 | 11,0 kW | 358 | 13,3 | 6" | 264 |
| DPFH R160 | 15,0 kW | 441 | 18,2 | 6" | 270 |
| DPFH R160 | 18,5 kW | 461 | 20 | 6" | 280 |
| DPHT R160 | 15,0 kW | 290 | 27 | 4" | 245 |
| DPHT R160 | 18,5 kW | 310 | 27 | 4" | 245 |

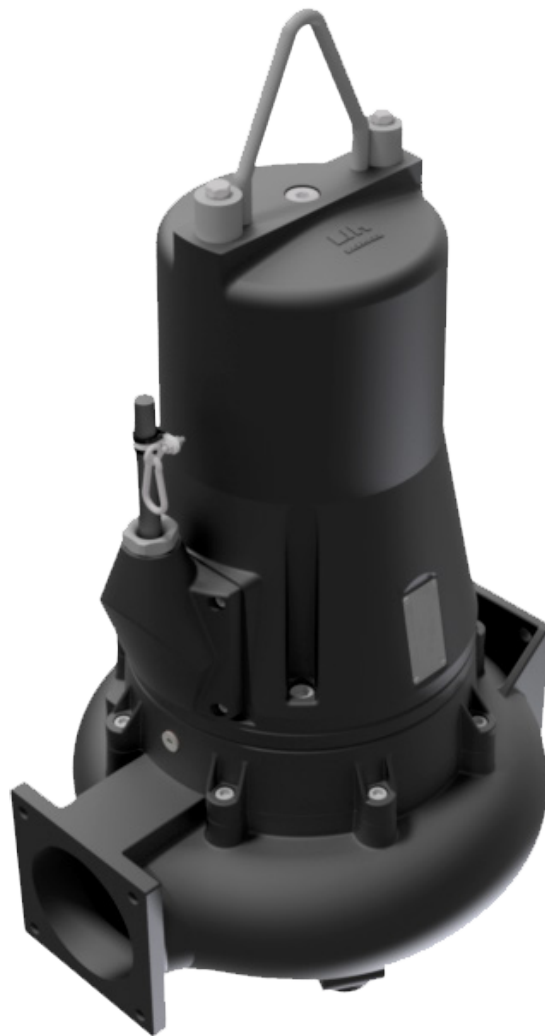

02.

DRY MOUNTED PUMPS

Where conditions are suitable, a dry mounted pump is an economically beneficial, highly durable and reliable solution.

Lind Jensen Agri's wide selection of slurry pumps, designed for dry mounting, are so flexible that we can always offer a pump that fits your needs.

This applies to all Lind Jensen dry mounted slurry pumps

- ✓ Built-in cutting system for the fine shredding of straw and feed residues
- ✓ Effective – also for liquid manure with very high dry matter
- ✓ Many sizes – from 5.5 kW to 18.5 kW

We can always
offer a pump that
fits your needs





| Model | kW | Max. capacity m3/h | Max. head | Outlet dimension | Weight kg. |
|-----------|---------|-----------------------|-----------|---------------------|------------|
| TPA S132 | 5,5 kW | 252 | 10,1 | 4" / 6" | 147 |
| TPA S132 | 7,5 kW | 265 | 14,5 | 4" / 6" | 150 |
| TPA S160 | 11,0 kW | 358 | 13,3 | 6" | 246 |
| TPA S160 | 15,0 kW | 441 | 18,2 | 6" | 273 |
| TPHT S180 | 18,5 kW | 351 | 27,5 | 4" | 293 |

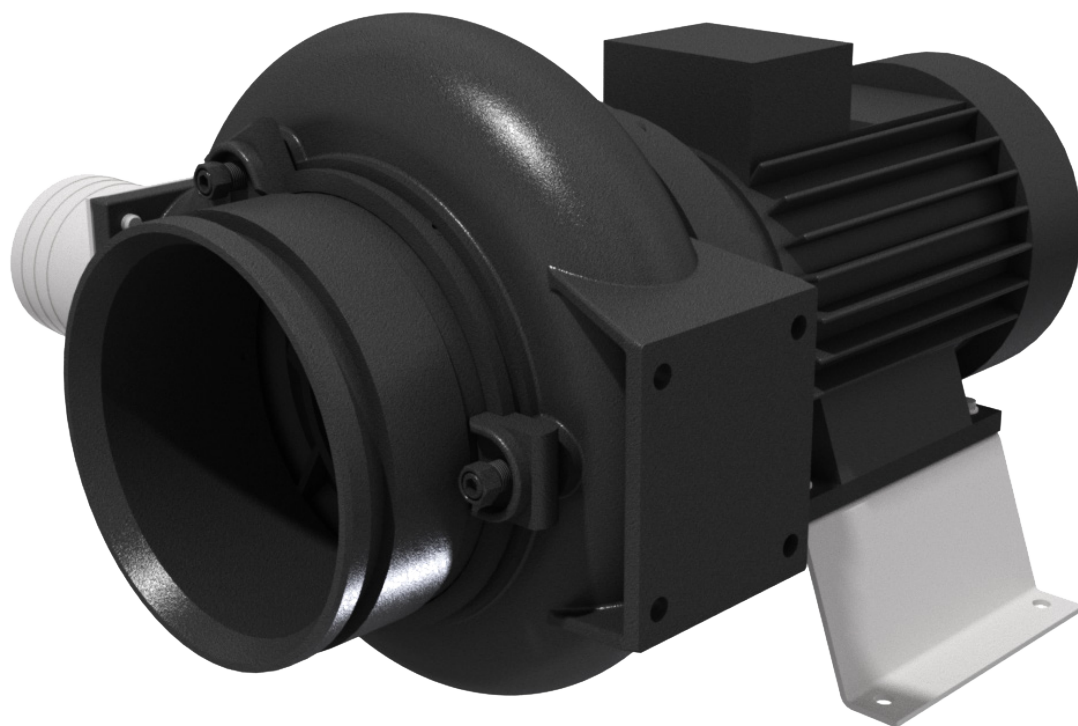

LJM - LIND JENSEN

QUALITY IS
THE **KEY**
IN ALL OUR
PRODUCTS



Lind Jensen Agri has more than 50 years of experience in the production and marketing of equipment of the highest quality for slurry handling. Every day we work goal-oriented to deliver the right product with the right quality and at the right price to our customers in Denmark and the rest of the world.

Lind Jensen Agri is one of the leading producers of equipment for slurry handling.

From the very beginning, Lind Jensen Agri's products have been at the core of the company's production, which also includes equipment for handling wastewater and biogas liquids and hydraulic cylinders for all needs. These product lines are produced and marketed in their own independent departments and the company employs more than 200 employees in departments in Denmark, China, India and the United States.

The design of the products for wastewater and biogas is based on products for the agricultural sector, while the hydraulics department delivers the hydraulic cylinders that are included in our automated scraper systems. We ourselves handle the whole process from development to production and delivery and servicing and thus ensure that we can always deliver very high quality products with long service intervals and a long lifetime.

Lind Jensen is ISO 9001 certified and works continually with LEAN principles to ensure a cost-effective production flow without sacrificing quality. All relevant staff are trained in Six-Sigma, where the aim is to achieve non-failure sales, production and delivery. At Lind Jensen, we want to be a flexible supplier that delivers the right products at the right price and with short delivery times. That is why fast and efficient service - before, during and after delivery - is crucial for us.

Many years of cooperation with our many customers in Denmark and abroad confirm that these business principles are appreciated by our customers. So, if you want to cooperate with a supplier with over 50 years of experience and know-how, Lind Jensen Agri is the right choice. Before, during and after delivery.



Lind Jensen Agri is one of the leading producers of equipment for slurry handling

Available in New Zealand from:

Prime Fluid Management
Head Office: 10 Chesterfield St
Greymouth, West Coast

0800 482 747

primefluid.co.nz

info@primefluid.co.nz

