



ZTND Series

End Suction Pumps

For heat carrier oils up to 350°C

TECHNICAL DATA

Output:	max. 1000 m ³ /h
Delivery head:	max. 95 m
Speed:	max. 3600 rpm
Temperature:	max. 350 °C
Casing pressure:	PN 16
Shaft sealing:	radial seal rings or mechanical seal
Flange connection:	DIN EN 1092-2 PN 16 / 25 ¹⁾
Direction of rotation:	clockwise, when looking at the pump from the drive end

APPLICATION

Volute pumps of the series ZTN have been specially developed for handling of mineral and synthetic heat transfer oils. The pumps may be used in installations with positive or negative suction pressure.

Especially to be emphasised is the application in plants of:

The chemical industry:

heating of agitators, reactors, drying plants, polymerisation plants, plants for conveying high-viscous products and producing plastic materials and synthetic fibres.

The rubber and plastic industry:

heating of calendars, melting pots, power presses for plastics, automatic injection moulding machines, production of PVC adhesive tape.

The food industry:

heating of baking and fish-frying ovens, distillation of fatty acids and glycerine, fat softening plants, production of potato chips and milk powder.

The paper industry and laundries:

calendar rolls, production of corrugated cardboard, heating of washing machines, mangles and dryers.

DESIGN

Horizontal, single-stage volute pumps with the dimensions and nominal ratings to 24255/EN 733 in back pull out design* which permits the removal of the complete bearing unit toward the drive end without removing the pump casing from the pipe work. If a spacer coupling is installed it is also unnecessary to disconnect the motor.

The programme comprises 38 pump sizes, but only three shaft assemblies are required owing to the unit construction system. Within each shaft assembly, shafts, shaft sealing, impeller fastenings, bearing bracket and bearing covers are interchangeable.

The DIN 4754 regulations are complied with.

Should heat carrier seepage occur from the shaft seal, it is ensured that the leakage will be drained off and collected completely.

1) from size 150315 to 200500

* due to additional sizes the performance range is increased to higher output rates.



CONSTRUCTION

Casing pressure:

Maximal 16 bar from 0 °C to 120 °C
Maximal 13 bar from 120 °C to 300 °C
Maximal 10 bar from 300 °C to 350 °C
Intermediate values can be obtained by interpolation.

Please note:

Technical rules and safety regulations.

Max. Casing pressure = inlet pressure + zero head

Admissible inlet pressure (system pressure) = 5 bar when using shaft sealing 002.

Admissible inlet pressure = admissible casing pressure when using shaft sealing GBC.

Flanges location:

Axial suction flange, discharge flange radially upwards.

Flanges:

The flanges comply with DIN EN1092-2/PN 16, resp. PN 25. Flanges drilled to according to ANSI (previous ASA) 150 can be supplied.

Hydraulic:

Designation of this construction type: A, B, D

Bearing:

One grease-lubricated grooved ball bearing resp. 2 inclined ball bearings (the first grease filling is made in the factory) and one internal liquid flushed sleeve bearing.

Designation of this construction type: -A

Direction of rotation:

Clockwise, when looking at the pump from the drive end.

Shaft sealing:

Code 002: several radial shaft seal rings arranged in series; uncooled

Code GBC: unbalanced bellows mechanical seal seal face materials cast chromium steel/carbon elastomer FPM (Viton)

ZTND Series

End Suction Pumps

For heat carrier oils up to 350°C



Material design:

ITEM	COMPONENTS	MATERIAL						EXECUTION	
		EN	EN	DIN	DIN	US denomination		1B	2B (1)
		mat.-number	mat.- denomination	mat.-number	mat.- denomination	ASTM Standard	AISI		
10.20	Volute casing	EN-JS 1025	EN-GJS-400-18-LT	0.7043	GGG-40.3	A 395		X	
		1.0619	GP 240 GH	1.0619	GS-C 25	A 216 Gr WCB			X
16.10	Casing cover	EN-JS 1025	EN-GJS-400-18-LT	0.7043	GGG-40.3	A 395		X	
		1.0619	GP 240 GH	1.0619	GS-C 25	A 216 Gr WCB			X
21.00	Shaft	1.1191	C 45 E	1.1191	Ck 45 K + N	A 576 Gr 1045	1045	X	
		1.4021	X 20 Cr 13	1.4021	X 20 Cr 13	A 276 Type 420	420	X (2)	X
23.00	Impeller	EN-JL 1040	EN-GJL 250	0.6025	GG-25	A 278 Class 30		X	X
33.00	Bearing bracket								
36.00	Bearing cover								
42.13	Radial seal rings	FPM (Viton)						X	X
43.30	Mechanical seal	chrome cast / carbon FPM (Viton)						X	X
44.10	Casing for mech. seal	1.1191	C 45 E	1.1191	Ck 45 K + N	A 576 Gr 1045	1045	X	X
44.11	Seal of the shaft casing								
54.51	Sleeve bearing	carbon						X	X

(1) For sizes 200400 and 200500.

(2) For sizes 150315, 150400, 150500, 200250 and 200315.

Casing gasket:

The casing is sealed by flat gaskets of graphite. Designation of this construction type: 2

Motor power:

Using commercial electric motors, type of construction IM B3.

To determine the drive power we recommend the following safety margin:

Up to 4 kW: 25% 4 to 7,5 kW: 20% above 7,5 kW: 15%

The following maximum speeds are to be observed:

max. speed n = 3600 rpm	size		max. speed n = 3000 rpm	size		max. speed n = 1800 rpm	size		max. speed n = 1500 rpm	size	
t = 120 °C	032125	050200	t = 120 °C	032250	040315	150315	t = 120 °C	150500	t = 120 °C		
	032160	065125		040250	050315	150400		200315			
	032200	065160		050250	065315	200250		200400			
	040125	065200		065250	080315						
	040160	080160		080250	100315						
	040200	080200		100250	125250						
	050125	100160		125200	150200						
050160	100200	150250	150250								
t = 350 °C	032125	050200	t = 350 °C	040250	040315	150250	t = 350 °C	150315	t = 350 °C		
	032160	065125		050250	050315			150400			
	032200	065160		065200	065315			150500			
	040125	080200		065250	080315			200250			
	040160	100160		080160	100315			200315			
	040200			080250	125200			200400			
	050125			100200	125250			200500			
	050160			100250	150200						
				100250	150200						
				100250	150200						

The maximum speeds result from the permissible peripheral speeds of the impellers or from the shaft load admissible at higher temperatures, respectively.

Bearing bracket / pump size:

Bracket 25	032125 032160 032200 032250 040125 040160 040200 040250 050125 050160 050200 050250 065125 065160 065200 080160
Bracket 35	040315 050315 065250 065315 080200 080250 080315 100160 100200 100250 100315 125200 125250 150200 150250
Bracket 45	150315 150400 150500 200250 200315 200400 200500

General remarks:

For horizontal volute pumps CLOSE COUPLED construction with STANDARD motor for nominal performances and flange connections as per EN 733 refer to our series ZTK.

For INLINE pumps with the same drive unit, consisting of bearing bracket with bearing, stub shaft and mechanical seal, casing cover, impeller and impeller nut, refer to our series ZTI.

For equipping hot media systems a complete programme is available for a flow range between 1-600 m³/h consisting of the range:

- ZEN** volute pumps to EN 22858, t_{max} 230 °C PN 40. Hot water design.
- ZDN** volute pumps to EN 22858, t_{max} 207 °C PN 25. Hot water design.
- ZNH** volute pumps to EN 733, t_{max} 180 °C PN 16. Hot water design.
- ZLI** volute pumps to EN 733 as INLINE construction, t_{max} 150 °C PN 25. Hot water design.

Technical documentation on these programmes will readily be supplied on request.



ZTND Series

End Suction Pumps

For heat carrier oils up to 350°C

SECTIONAL DRAWING AND NOMENCLATURE ZTN 032125 ... 150250

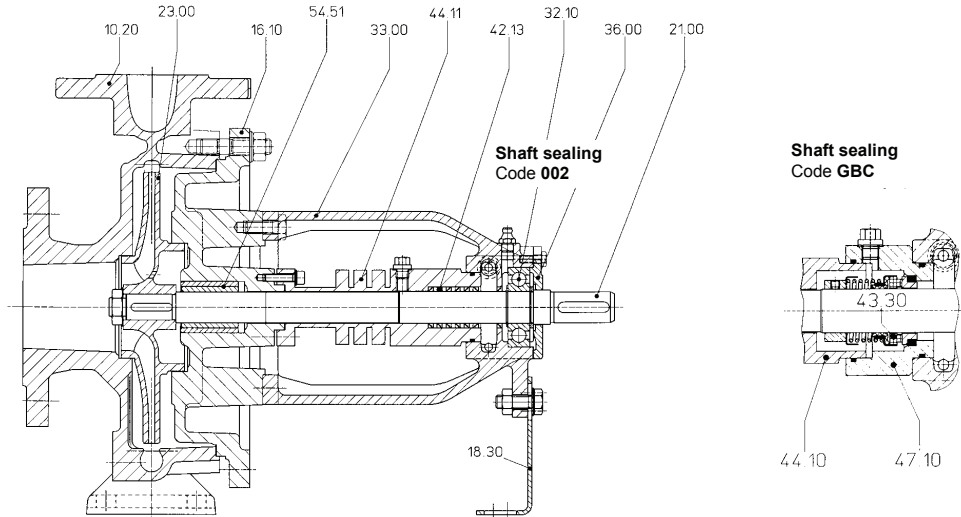

- 10.20 volute casing
- 16.10 casing cover
- 18.30 supporting foot
- 21.00 shaft
- 23.00 impeller
- 32.10 grooved ball bearing
- 33.00 bearing bracket
- 36.00 bearing cover
- 42.13 radial seal ring
- 43.30 mechanical seal
- 44.10 shaft seal casing
- 44.11 shaft seal casing
- 47.10 sealing cover
- 54.51 sleeve bearing

ZTN 150315 ... 200500

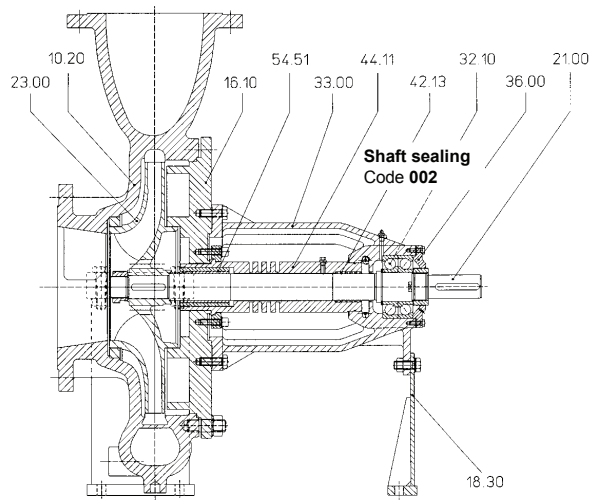

Heat barrier / shaft sealing / bearing

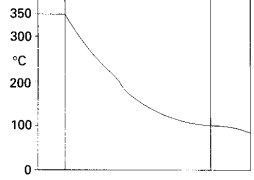
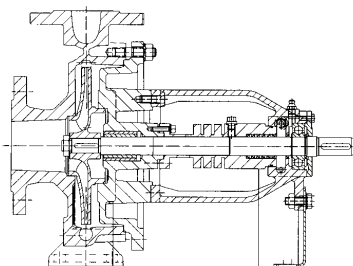

Heat transfer installations have achieved a high level of technical development. Consequently the requirements on pumps handling heat transfer oils have increased regarding operating safety, environmental protection, maintenance and operating costs. The Sterling SIHI ZTN pump, based on many years of experience and on the latest technical know-how, fully complies with these requirements.

By the heat barrier with integrated throttle gap, located behind the cover, a favourable drop in temperature toward the drive side is achieved (see opposite drawing). Heat losses at the product side are effectively prevented (saving of energy). The reduced temperature allows the use of simple, uncooled type of shaft sealing. As the lubricating properties of heat transfer oils for antifriction bearings are not specially good, a liquid flushed sleeve bearing has been fitted at the impeller side and an antifriction bearing, not in contact with the heat carrier, has been fitted behind the shaft sealing. By this arrangement noiseless operation and long working life have

been achieved.

ZTND Series

End Suction Pumps

For heat carrier oils up to 350°C



Performance graph

50 Hz

n=2900 1/min

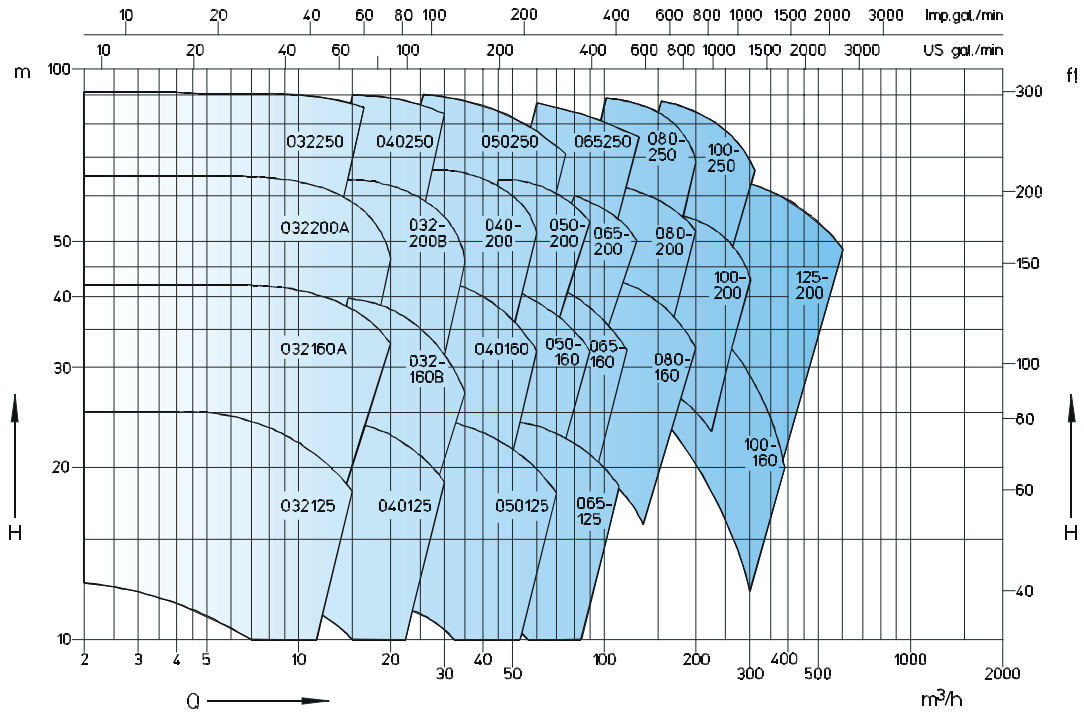

n=1450 1/min

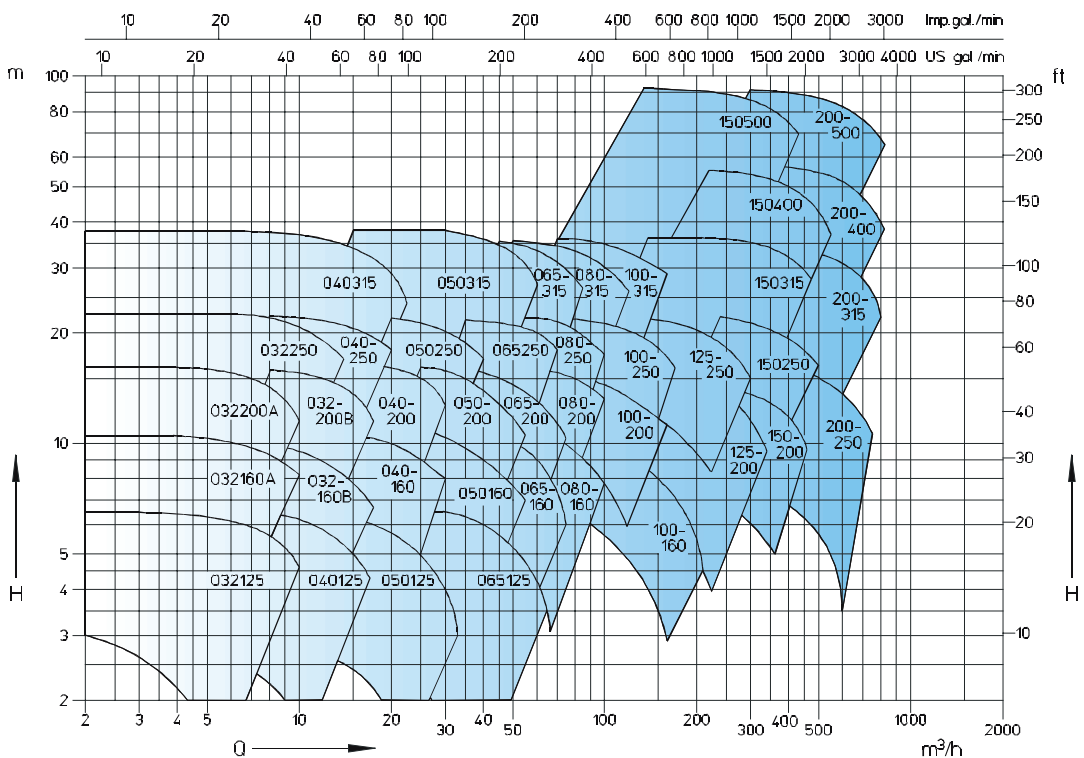



ZTND Series

End Suction Pumps

For heat carrier oils up to 350°C

Performance graph

60 Hz

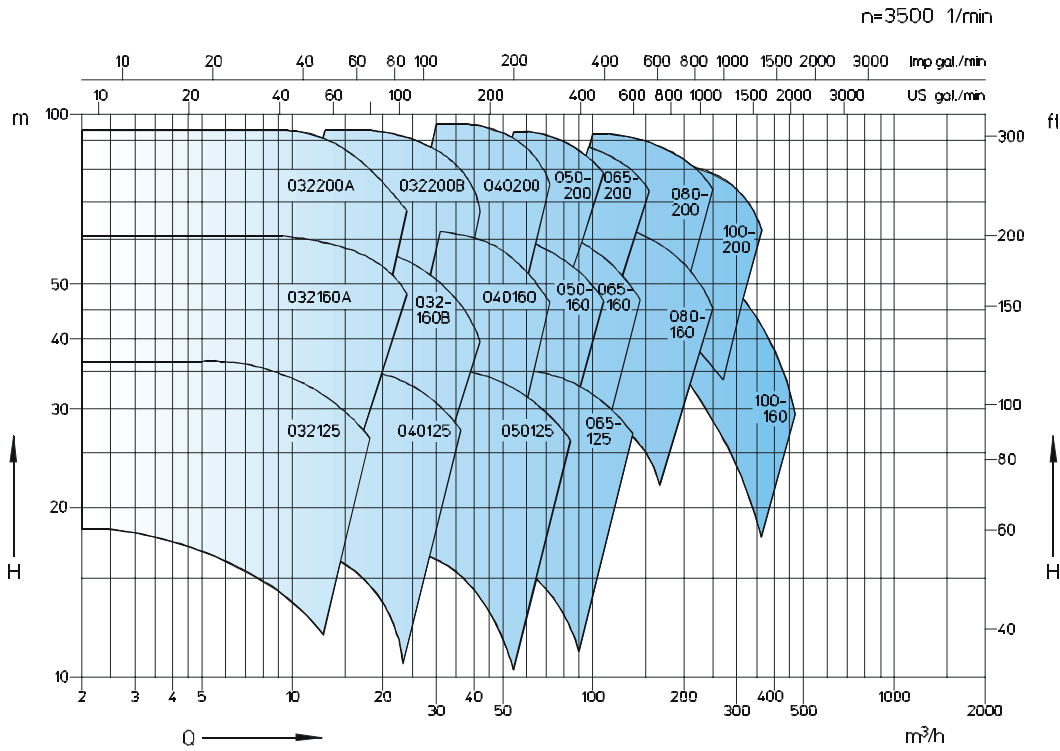

n=1750 1/min

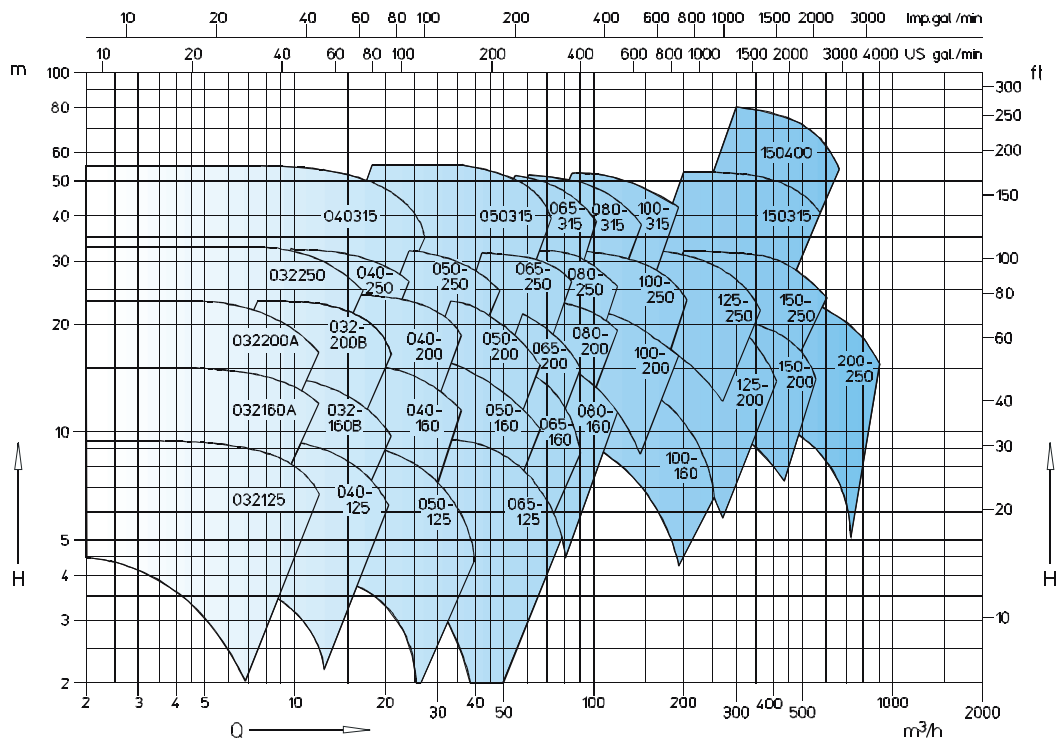

Available in New Zealand from:

Prime Fluid Management

Head Office: 10 Chesterfield St

Greymouth, West Coast

0800 482 747

primefluid.co.nz

