

TMA Series

Multistage Centrifugal Pumps



Capacity from 1 to 45 m³/h
Total head from 4 to 40 bar



TMA Series

Multistage Centrifugal Pumps



Main applications

- Boiler feed
- For handling clean or slightly dirty liquids
- For heating plants
- Water supply piping
- Autoclaves
- Fire fighting operations
- Agriculture and irrigation

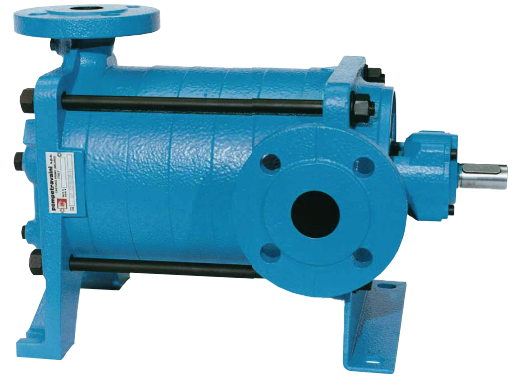

Construction

The TMA series pumps are multistage centrifugal type pumps that employ a closed type impeller design. The impellers are in series so that the head increases as the liquid being pumped is transferred from each impeller.

On the TMA series, the axial thrusts are balanced by balancing blades on the back of the impeller. The remaining thrust forces are absorbed by the heavy duty single ball bearing at the non-drive end and angular bearings at the drive end. For pump designs that have two external bearings, a pressure pipe is provided to relieve pressures in the seal area from the discharge side of the pump to the suction side.

The TMA pump design uses the latest foundry technologies. This allows for one piece components which effectively increases pump efficiencies, at the same time, reducing the weight of the pump without sacrificing the overall strength and durability. For the smaller TMA 31 & 32 series a close coupled design is available where space is limited. This design also eliminates any concerns for misalignment, which enhance the pump's performance and extend

Limits of use

- Capacity from 1 to 45 m³/h
- Head from 40 to 400 m.
- Temperature tolerance: max 120°C (250°F) without cooled stuffing boxes, 160°C (320°F) with cooled stuffing boxes.

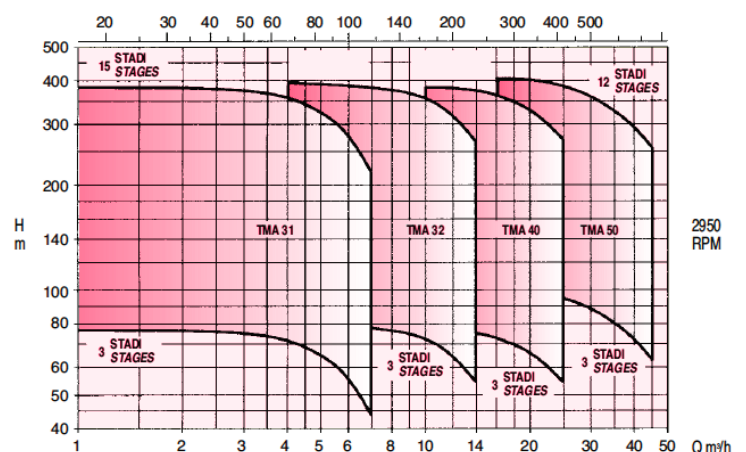

Not binding data refers to water at room temperature.
For specific performance curves contact POMPETRAVAINI.

TMA Series

Multistage Centrifugal Pumps



EXAMPLE OF MODEL DESIGNATION

T M A 32 - 4 A / 2X - C / A3 - M / T - V - Z

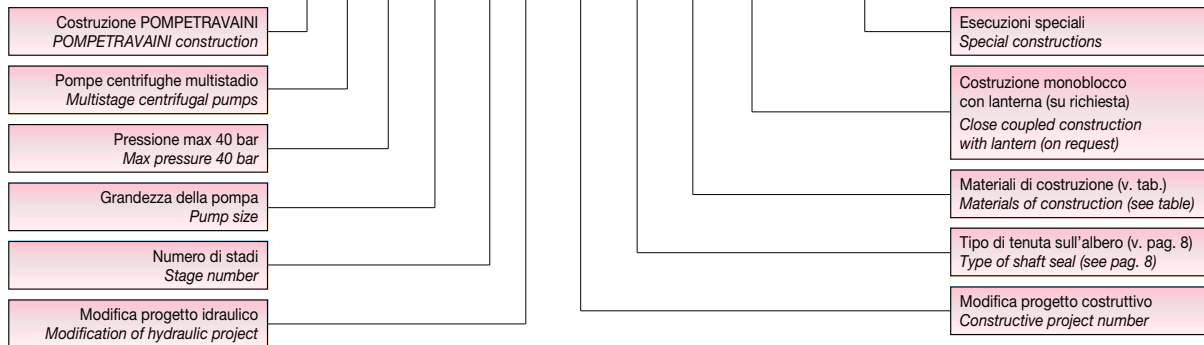

STANDARD MATERIALS OF CONSTRUCTION

VDMA N°	Descrizione Description	F	RA	A3*
106	Corpo aspirante Suction casing	Ghisa sferoidale Ductile iron		
107	Corpo premente Discharge casing			
108.1	Diffusore Diffuser	Ghisa Cast iron		
210	Albero Shaft	Acciaio inox AISI 420 AISI 420 Stainless steel	Acciaio inox AISI 316 AISI 316 Stainless steel ASTM-CF8M	
230	Girante Impeller			
350 - 353 - 357	Supporto Bearing housing	Ghisa Cast iron		
524	Bussola albero Shaft sleeve	Acciaio inox AISI 316 AISI 316 Stainless steel	ASTM-CF8M	

MATERIALI SPECIALI SU RICHIESTA - Tabella indicativa: per informazioni più dettagliate consultare il ns. Ufficio Commerciale
SPECIAL MATERIALS AVAILABLE UPON REQUEST - Indicative table: for further information pls consult our Sales Office

* Attualmente disponibile solo per pompe serie TMA 40 e 50
Actually available only for pumps series TMA 40 and 50

PRESSURE AND TEMPERATURE LIMITS

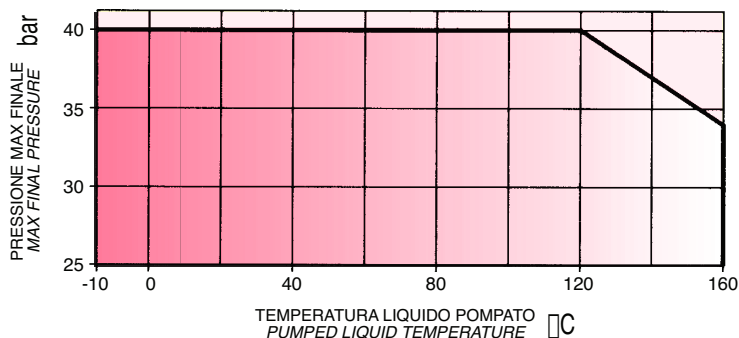

The showed value of maximum pressure is the sum of the suction pressure and the head without capacity.
Limits valid for constructions **F, RA, A3**.

TMA Series

Multistage Centrifugal Pumps



PERFORMANCE DATA AT 2950 RPM

Data refers to water at room temperature.
For specific performance curves contact
POMPETRAVINI.

Tolleranze Tolerances	Materiali di costruzione Construction materials	
	F - RA	A3
Q = Portata in m ³ /h Capacity in m ³ /h	± 5%	± 5%
H = Prevalenza totale in m Head in m	± 5%	- 10%
kw = Potenza assorbita all'asse Absorbed power	+ 10%	+ 10%

PORTATA CAPACITY Q	m ³ /h lit/1'	1		2		3		4		5		6		7		H	kW	H	kW	H	kW
		16,6	33,3	50	66,6	83,3	100	116,6													
TIPO - MODEL		H	kW	H	kW	H	kW	H	kW	H	kW	H	kW	H	kW						
TMA 31-3/2		76,5	1,8	75	2,1	73,5	2,2	70,5	2,4	64,5	2,5	57	2,6	43,5	2,7						
TMA 31-4/2		102	2,4	100	2,8	98	2,9	94	3,1	86	3,3	76	3,5	58	3,6						
TMA 31-5/2		127,5	3,1	125	3,4	122,5	3,6	117,5	3,9	107,5	4,1	95	4,4	72,5	4,4						
TMA 31-6/2		153	3,6	150	4,1	147	4,4	141	4,7	129	4,9	114	5,3	87	5,3						
TMA 31-7/2		178,5	4,2	175	4,7	171,5	5,1	164,5	5,5	150,5	5,7	133	6,1	101,5	6,2						
TMA 31-8/2		204	4,8	200	5,5	196	5,8	188	6,2	172	6,5	152	7,1	116	7,2						
TMA 31-9/2		229,5	5,5	225	6,1	220,5	6,6	211,5	7,1	193,5	7,3	171	7,9	130,5	8,1						
TMA 31-10/2		255	6,1	250	6,8	245	7,3	235	7,8	215	8,1	190	8,8	145	8,9						
TMA 31-11/2		280,5	6,7	275	7,5	269,5	8,1	258,5	8,6	236,5	8,9	209	9,7	159,5	9,8						
TMA 31-12/2		306	7,3	300	8,2	294	8,8	282	9,4	258	9,8	228	10,5	174	10,7						
TMA 31-13/2		331,5	7,9	325	8,9	318,5	9,5	305,5	10,2	279,5	10,6	247	11,4	188,5	11,6						
TMA 31-14/2		357	8,5	350	9,5	343	10,3	329	11	301	11,4	266	12,3	203	12,5						
TMA 31-15/2		382,5	9,2	375	10,3	367,5	11	352,5	11,8	322,5	12,2	285	13,2	217,5	13,4						
NPSH	m		1,4		1,5		1,55		1,6		1,7		1,75		1,85						

PORTATA CAPACITY Q	m ³ /h lit/1'	4		6		8		10		12		14		H	kW	H	kW	H	kW	H	kW
		66,6	100	133,3	166,6	200	233,3														
TIPO - MODEL		H	kW	H	kW	H	kW	H	kW	H	kW	H	kW								
TMA 32-3/2		79,5	2,4	78,7	2,8	76	3,1	72	3,4	65	3,8	54	4								
TMA 32-4/2		106	3,3	105	3,7	101,5	4,2	96	4,6	86,5	5	72,5	5,3								
TMA 32-5/2		132,5	4,1	131	4,7	127	5,3	120	5,8	108	6,3	90,6	6,7								
TMA 32-6/2		159	5	157,5	5,6	152	6,3	144	7	130	7,5	108,7	8,1								
TMA 32-7/2		185,5	5,8	183,7	6,5	177,5	7,3	168	8,1	151	8,9	126,8	9,4								
TMA 32-8/2		212	6,6	210	7,5	203	8,3	192	9,2	173	10,1	145	10,7								
TMA 32-9/2		238,5	7,4	236	8,4	228	9,4	216	10,4	194,5	11,4	163	12								
TMA 32-10/2		265	8,2	262,5	9,4	253,5	10,5	240	11,6	216	12,7	181,2	13,3								
TMA 32-11/2		291,5	9,1	288,7	10,3	279	11,6	264	12,7	238	13,9	199,3	14,7								
TMA 32-12/2		318	9,9	315	11,2	305	12,6	288	13,9	259,5	15,2	217,5	16,1								
TMA 32-13/2		344,5	10,7	341,2	12,2	330	13,7	312	15	281	16,4	235,6	17,4								
TMA 32-14/2		371	11,5	367,5	13,1	355	14,7	337	16,1	302	17,8	253,7	18,8								
TMA 32-15/2		397,5	12,3	393,7	13,9	380,5	15,7	360	17,3	324	19	271,8	20,1								
NPSH	m		1,6		1,75		1,85		2,2		2,7		3,2								

PORTATA CAPACITY Q	m ³ /h lit/1'	10		12		14		16		18		21		25		H	kW	H	kW	H	kW
		166,6	200	233,3	266,6	300	350	416,6													
TIPO - MODEL		H	kW	H	kW	H	kW	H	kW	H	kW	H	kW	H	kW						
TMA 40-3/5		76,5	4,6	76,5	5	73,8	5,4	72	5,7	69	6	63	6,5	53,4	7						
TMA 40-4/5		102	6,1	100,8	6,6	98,4	7,1	96	7,5	92	8	84	8,6	71,2	9,3						
TMA 40-5/5		127,5	7,7	126	8,3	123	8,9	120	9,5	115	10	105	10,8	89	11,7						
TMA 40-6/5		153	9,2	151,2	10	147,6	10,7	144	11,4	138	12	126	13	106,8	13,9						
TMA 40-7/5		178,5	10,8	176,4	11,6	172,2	12,5	168	13,3	161	14	147	15,2	124,6	16,3						
TMA 40-8/5		204	12,3	201,6	13,3	196,8	14,2	192	15,1	184	16	168	17,3	142,4	18,6						
TMA 40-9/5		229,5	13,9	226,8	14,9	221,4	16,1	216	17	207	18	189	19,5	160,2	20,9						
TMA 40-10/5		255	15,4	252	16,6	246	17,8	240	18,9	230	20	210	21,7	178	23,3						
TMA 40-11/5		280,5	17	277,2	18,3	270,6	19,6	264	20,9	253	22	231	23,9	195,8	25,6						
TMA 40-12/5		306	18,5	302,4	19,9	295,2	21,4	288	22,8	276	24,1	252	26	213,6	27,9						
TMA 40-13/5		331,5	20	327,6	21,6	319,8	23,2	312	24,6	299	26,1	273	28,2	231,4	30,3						
TMA 40-14/5		357	21,7	352,8	23,2	344,4	25	336	26,5	322	28,1	295	30,3	249,2	32,6						
TMA 40-15/5		382,5	23,1	378	24,9	369	26,8	360	28,4	345	30,1	315	32,5	267	35						
NPSH	m		1,5		1,8		2,4		2,6		3,5		4,5		6						

PORTATA CAPACITY Q	m ³ /h lit/1'	16		20		25		30		35		40		45		H	kW	H	kW	H	kW
		266,6	333,3	416,6	500	583,3	666,6	750													
TIPO - MODEL		H	kW	H	kW	H	kW	H	kW	H	kW	H	kW	H	kW						
TMA 50-3/5		100,5	9	99	9,7	94,5	10,6	88,2	11,7	80,4	12,6	72	13,4	61,5	13,9						
TMA 50-4/5		134	12	132	12,9	126	14,2	117,5	15,6	107,2	16,9	96	17,8	82	18,6						
TMA 50-5/5		167,5	15	165	16,1	157,5	17,7	147	19,5	134	21	120	22,2	102,5	23,2						
TMA 50-6/5		201	18	198	19,4	189	21,2	176,5	23,4	160,8	25,3	144	26,7	123	27,8						
TMA 50-7/5		234,5	21,1	231	22,6	220,5	24,7	205,8	27,2	187,6	29,5	168	31,1	143,5	32,5						
TMA 50-8/5		268	24,1	264	25,9	252	28,3	235,2	31,1	214,4	33,8	192	35,6	164	37,2						
TMA 50-9/5		301,5	27,1	297	29,1	283,5	31,9	264,6	35	241,2	38	216	40	184,5	41,8						
TMA 50-10/5		335	30,1	330	32,3	315	35,4	294	38,9	268	42,1	240	44,5	205	46,8						
TMA 50-11/5		368,5	33,1	363	35,6	346,5	38,9	323,4	42,8	294,8	46,4	264	48,9	225,5	51,1						
TMA 50-12/5		402	36,1	396	38,8	378	42,5	352,8	46,7	321,6	50,7	288	53,4	246	55,8						
NPSH	m		1,5		1,6		2,1		2,6		3		3,8		4,7						

TMA Series

Multistage Centrifugal Pumps



TYPICAL CROSS SECTIONS

COMPONENTS

VDMA No	DESIGNATION
106	Suction casing
107	Discharge casing
108.1	Diffuser
165	Cooling chamber cover
181	Support plate
184	Adaptor flange
185	Motor flange
210	Shaft
230	Impeller
310	Sleeve
320...	Ball bearing
321	Double row ball bearing
341	Motor stool
350...	Bearing housing
357...	Bearing and mechanical seal housing
433.2	Mechanical seal
452	Gland
461	Gland packing
471	Mechanical seal cover
502	Wear ring (A3 construction only)
523	Shaft sleeve
524	Shaft sleeve
525	Shaft sleeve

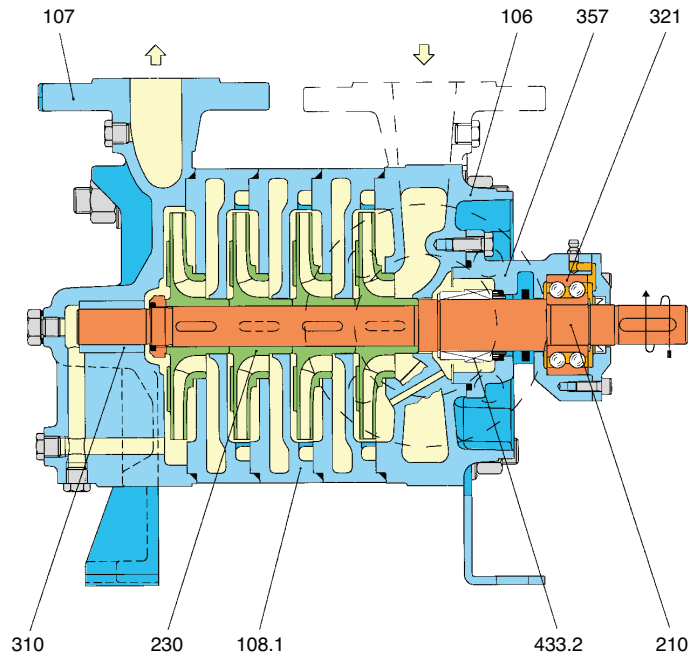

Pump series TMA 31 and 32 with single mechanical seal (design ...R)

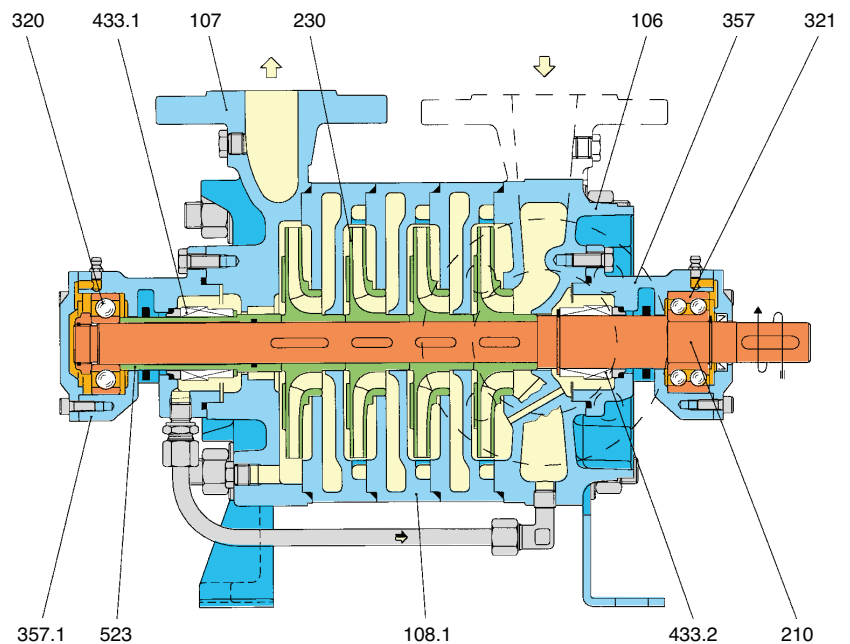

Pump series TMA 31 and 32 with 2 single mechanical seals (design ...C)

TMA Series

Multistage Centrifugal Pumps



TYPICAL CROSS SECTIONS

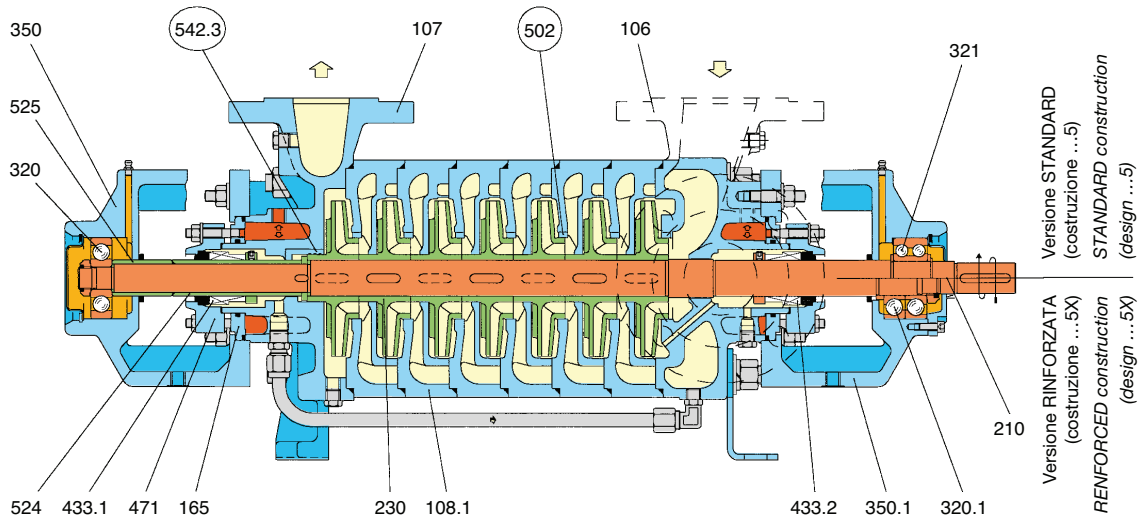

Pompa serie TMA 40 e 50 con 2 tenute meccaniche semplici (costruzione ...C)
Pump series TMA 40 and 50 with 2 single mechanical seals (design ...C)

○ Solo costruzione A3
A3 construction only

Pompa serie TMA 31 e 32 - esecuzione verticale (costruzione ...M-V)
Pump series TMA 31 and 32 - vertical construction (design ...M-V)

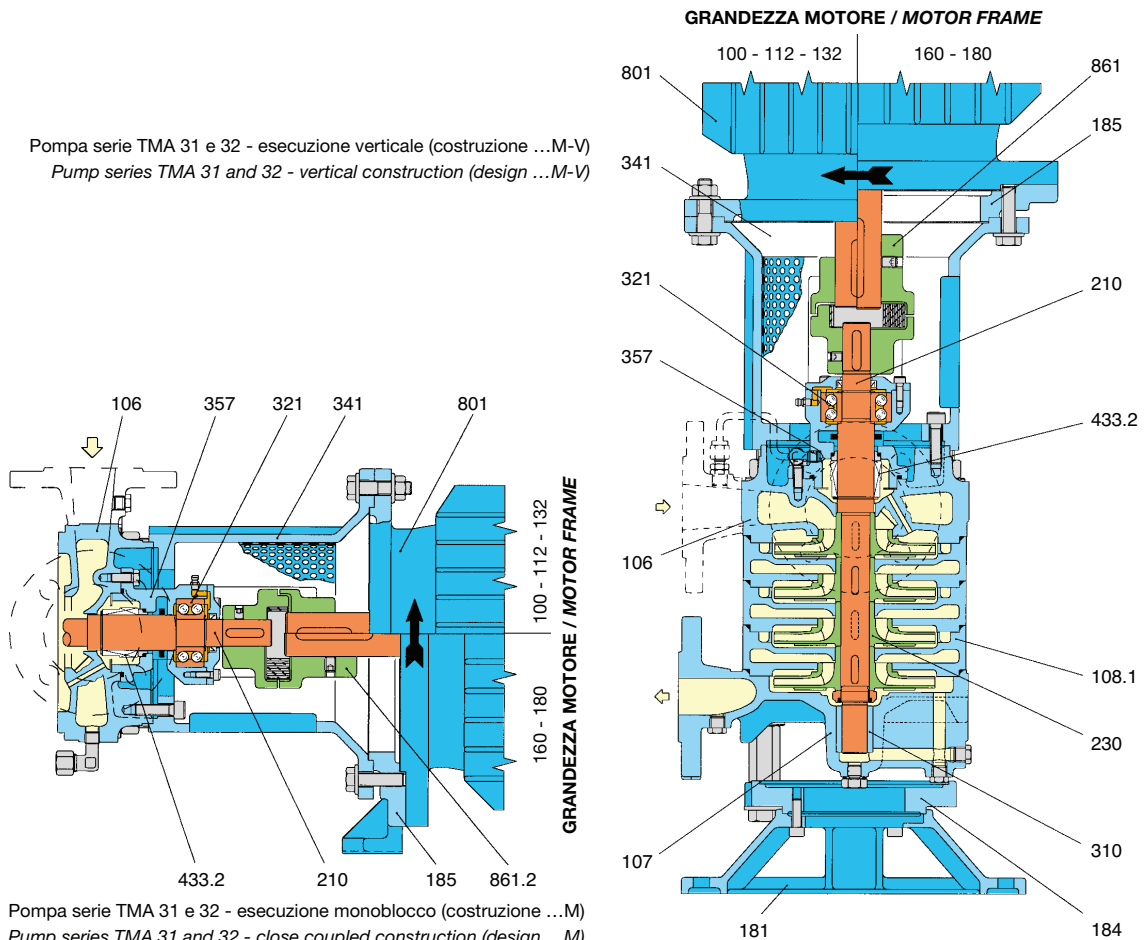

Pompa serie TMA 31 e 32 - esecuzione monoblocco (costruzione ...M)
Pump series TMA 31 and 32 - close coupled construction (design ...M)

TMA Series

Multistage Centrifugal Pumps



TMA pump series can be fitted with any type of mechanical seal that is unified to the ISO 3069/UNI EN 12756 standards. Single mechanical seals, double mechanical seals in tandem or back to back arrangements can be fitted. The pump bearing frame offers versatility and plenty of space to also allow fitting special types of mechanical seals that may not have unified dimensions or, for pumps series TMA 40 and 50 only, cartridge type seals.

TMA 31 & 32 Series

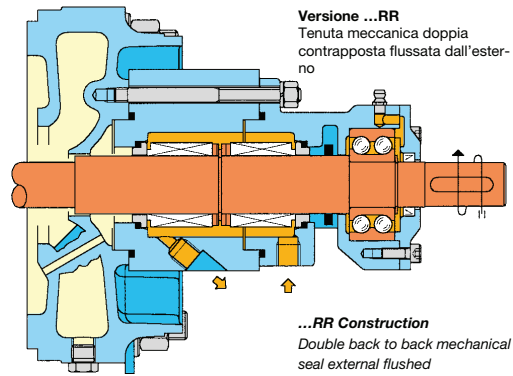
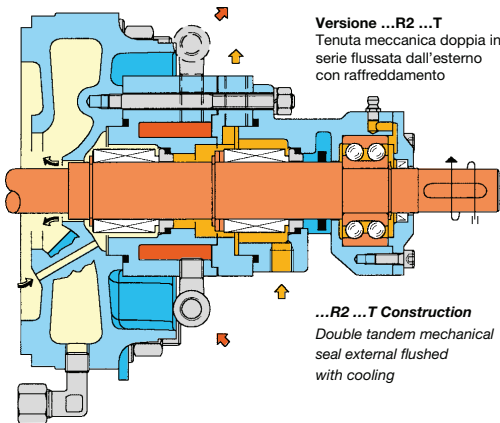

TMA 40 & 50 Series

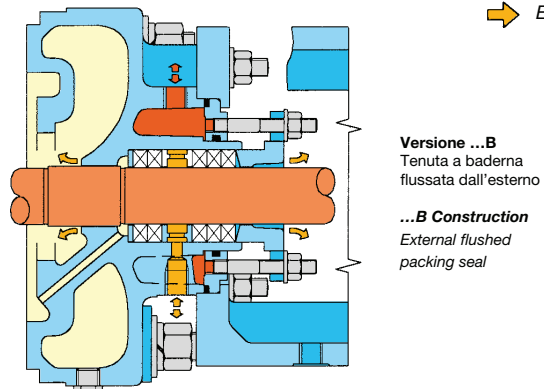
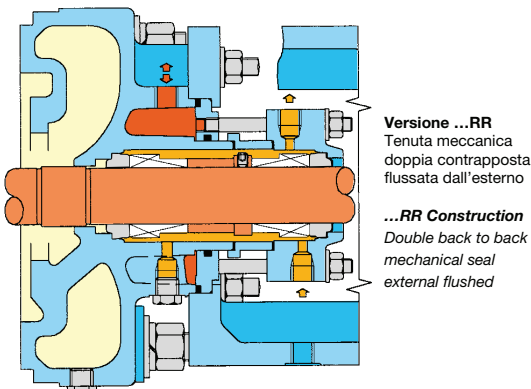
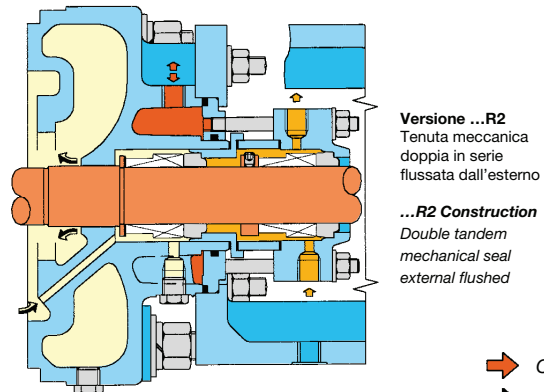
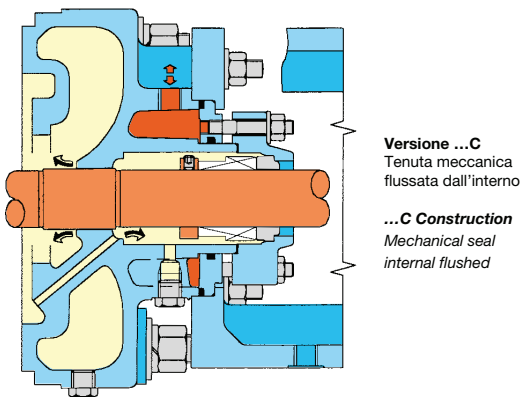

- Cooling or heating liquid
- Internal washing liquid
- External washing liquid

TMA Series

Multistage Centrifugal Pumps



TMA 31 & 32 SERIES

* Construction C

* Construction R

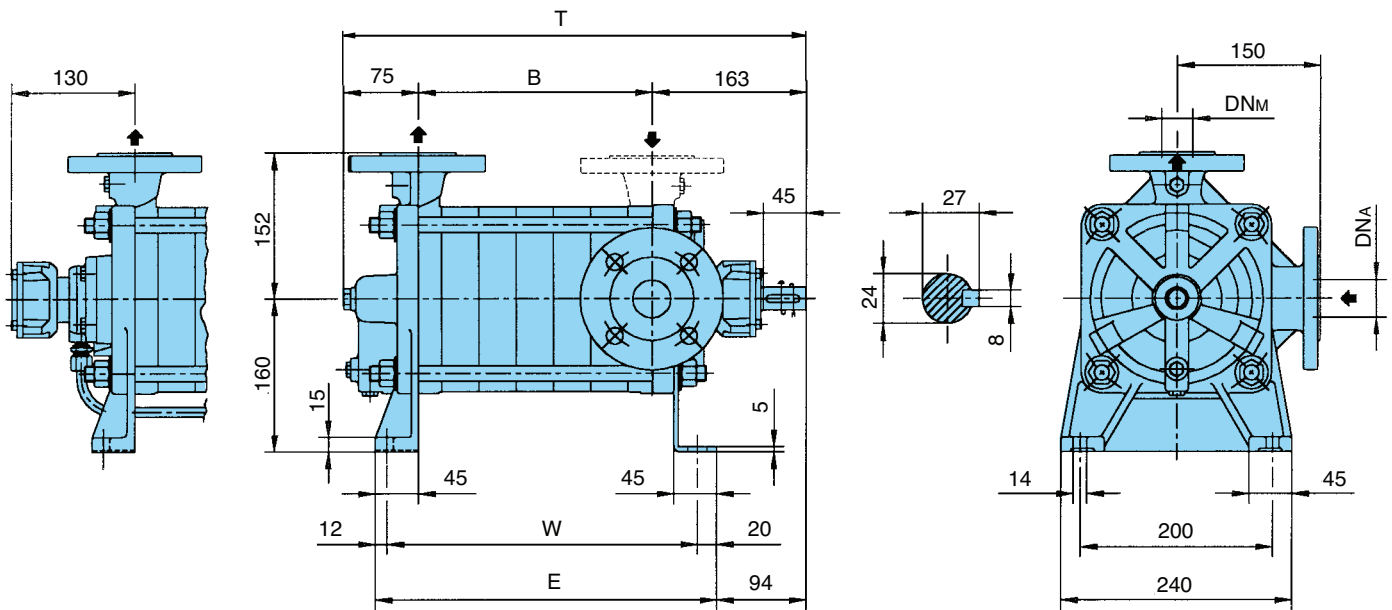

Pompa tipo Pump model	Versione ad ASSE NUDO BARESHAFT construction						Peso Weight
	DNA	DNM	B	T	W	E	
TMA 31-3 & 32-3	40	32	125	363	205	237	35
TMA 31-4 & 32-4	40	32	164	402	244	276	40
TMA 31-5 & 32-5	40	32	203	441	283	315	45
TMA 31-6 & 32-6	40	32	242	480	322	354	50
TMA 31-7 & 32-7	40	32	281	519	361	393	55
TMA 31-8 & 32-8	40	32	320	558	400	432	60
TMA 31-9 & 32-9	40	32	359	597	439	471	65
TMA 31-10 & 32-10	40	32	398	636	478	510	70
TMA 31-11 & 32-11	40	32	437	675	517	549	75
TMA 31-12 & 32-12	40	32	476	714	556	588	80
TMA 31-13 & 32-13	40	32	515	753	595	627	85
TMA 31-14 & 32-14	40	32	554	792	634	666	90
TMA 31-15 & 32-15	40	32	593	831	673	705	95

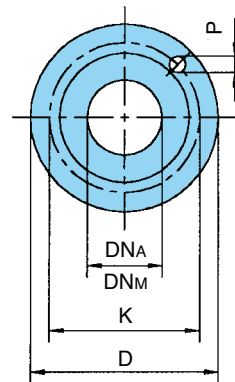

FLANGES:
Flanges ND32 dimensions to UNI 2223-2229 NP40 standards
Flanges ND40 dimensions to UNI 2223-2229 NP16 standards

FLANGES DIMENSIONS

DNA - DNM	D	K	P	N. Fori Holes
32	140	100	18	4
40	150	110	18	4

* Construction R is available up to TMA 31-9 and 32-9 version, construction C is available up to TMA 31-15 and 32-15 version.
Schematic drawing. Dimensions in mm with tolerance to EN 735-1995 standards. Weights in kgs. referred to pump in cast iron "F" construction, not binding.

TMA Series

Multistage Centrifugal Pumps



TMA 31 & 32 SERIES

CLOSE COUPLED ...CM and ...RM construction

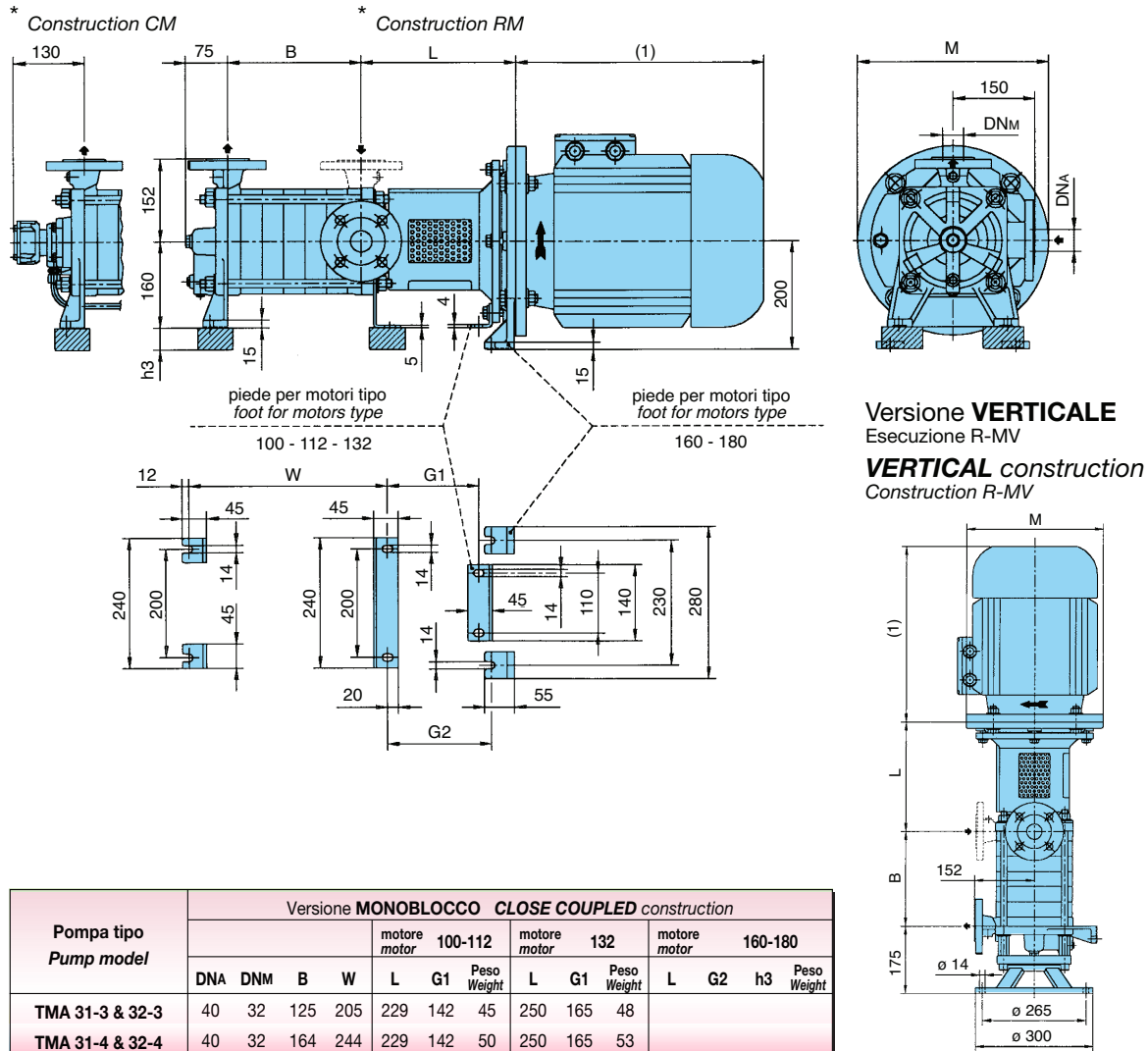

Versione VERTICALE
Esecuzione R-MV
VERTICAL construction
Construction R-MV

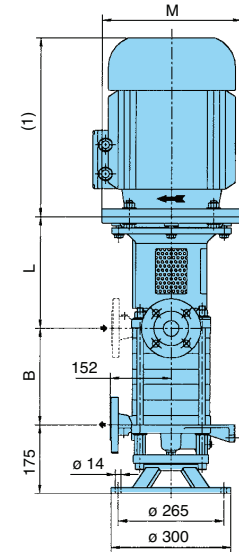

Pompa tipo Pump model	Versione MONOBLOCCO CLOSE COUPLED construction													
	motore motor 100-112			motore motor 132			motore motor 160-180							
	DNA	DNM	B	W	L	G1	Peso Weight	L	G1	Peso Weight	L	G2	h3	Peso Weight
TMA 31-3 & 32-3	40	32	125	205	229	142	45	250	165	48				
TMA 31-4 & 32-4	40	32	164	244	229	142	50	250	165	53				
TMA 31-5 & 32-5	40	32	203	283	229	142	55	250	165	58				
TMA 31-6 & 32-6	40	32	242	322	229	142	60	250	165	63	279	187	40	75
TMA 31-7 & 32-7	40	32	281	361				250	165	68	279	187	40	80
TMA 31-8 & 32-8	40	32	320	400				250	165	73	279	187	40	85
TMA 31-9 & 32-9	40	32	359	439				250	165	78	279	187	40	90
TMA 31-10 & 32-10	40	32	398	478				250	165	83	279	187	40	95
TMA 31-11 & 32-11	40	32	437	517							279	187	40	100
TMA 31-12 & 32-12	40	32	476	556							279	187	40	105
TMA 31-13 & 32-13	40	32	515	595							279	187	40	110
TMA 31-14 & 32-14	40	32	554	634							279	187	40	115
TMA 31-15 & 32-15	40	32	593	673							279	187	40	120

ELECTRIC MOTORS

Grandezza Frame size IEC	Giri/min. RPM 2900 kW	M
100 L	3	250
112 M	4	250
132 M	5,5 - 7,5	300
160 M	11 - 15	350
160 L	18,5	350
180 M	22	350

(1) Dimensioni in funzione della marca del motore installato.
(1) Not binding dimensions according to installed motor supplier.

(h3) Spessori per allineamento motore - pompa, esclusi dalla fornitura.
(h3) Spacers for motor - pump alignment are not supplied by pompetravaini.

* L'esecuzione **RM** è disponibile fino alla versione **TMA 31-9** e **32-9**, l'esecuzione **CM** è disponibile fino alla versione **TMA 31-15** e **32-15**.

Disegno schematico. Dimensioni in mm con tolleranze secondo **EN 735-1995**. Pesi indicativi in kg, riferiti a pompe in esecuzione "**F**" ghisa escluso motore, non impegnativi. Per le dimensioni delle flange vedere la versione ad **ASSE NUDO** a pag. 9.

* Construction **RM** is available up to **TMA 31-9** and **32-9** version, construction **CM** is available up to **TMA 31-15** and **32-15** version.

Schematic drawing. Dimensions in mm with tolerance to **EN 735-1995** standards. Weights in kgs. referred to pump in cast iron "**F**" construction without motor, not binding. For flanges dimensions see **BARESHAFT** construction at page 9.

TMA Series

Multistage Centrifugal Pumps



TMA 40 & 50 SERIES

BARESHAFT construction

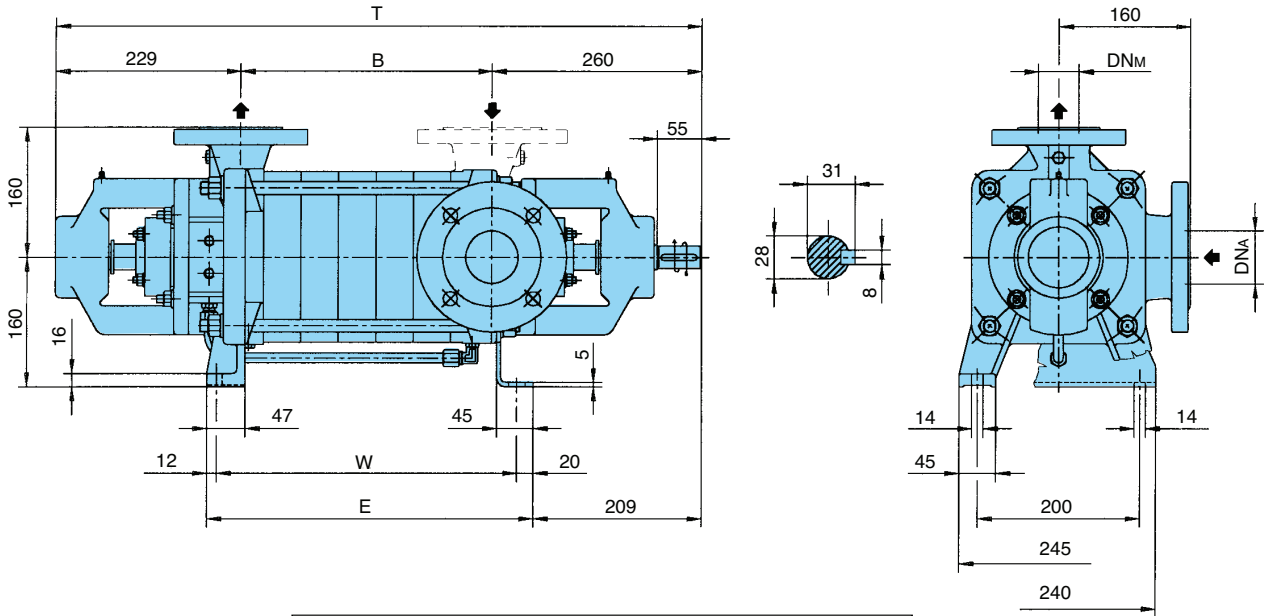

Comando albero della costruzione ...5X
Shaft drive end of construction ...5X

Pompa tipo Pump model	Versione ad ASSE NUDO BARESHAFT construction						TMA 40	TMA 50
	DNA	DNM	B	T	W	E	Peso Weight	Peso Weight
TMA 40-3 & 50-3	65	50	171	660	231	263	88	86
TMA 40-4 & 50-4	65	50	217	706	277	309	95	92
TMA 40-5 & 50-5	65	50	263	752	323	355	102	98
TMA 40-6 & 50-6	65	50	309	798	369	401	109	104
TMA 40-7 & 50-7	65	50	355	844	415	447	116	110
TMA 40-8 & 50-8	65	50	401	890	461	493	123	116
TMA 40-9 & 50-9	65	50	447	936	507	539	130	122
TMA 40-10 & 50-10	65	50	493	982	553	585	137	128
TMA 40-11 & 50-11	65	50	539	1028	599	631	144	134
TMA 40-12 & 50-12	65	50	585	1074	645	677	151	140
TMA 40-13	65	50	631	1120	691	723	158	-
TMA 40-14	65	50	677	1166	737	769	165	-
TMA 40-15	65	50	723	1212	783	815	172	-

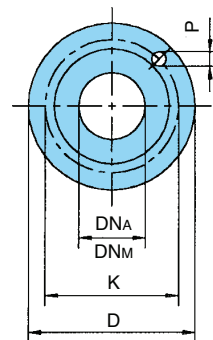

FLANGES:
Flanges ND50 dimensions to
UNI 2223-2229 NP40 standards
Flanges ND65 dimensions to
UNI 2223-2229 NP16 standards

FLANGES DIMENSIONS

DNA - DNM	D	K	P	N. Fori Holes
50	165	125	18	4
65	185	145	18	4

TMA Series

Multistage Centrifugal Pumps

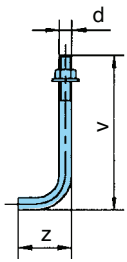
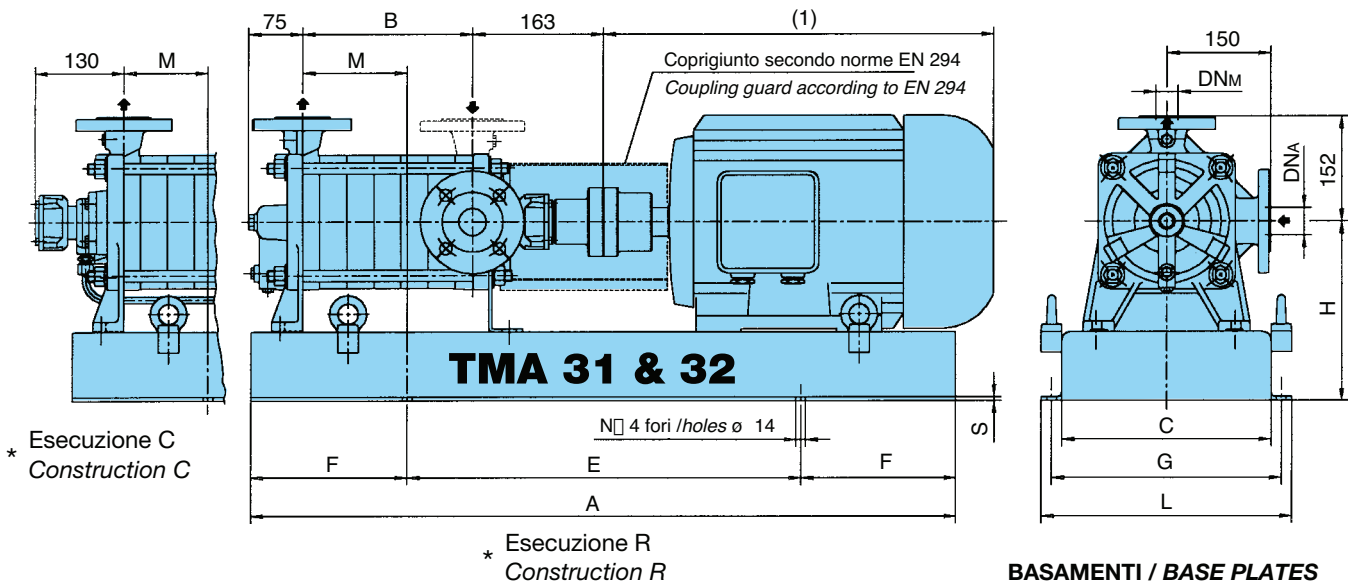

BULLONI DI FONDAZIONE
(OPTIONAL)
FOUNDATION BOLTS

d	v	z
M12	240	45

BASAMENTI / BASE PLATES

N°	A	C	E	F	L	G	S
900	960	310	600	180	380	340	5
901	770	290	420	175	350	320	5
903	1170	350	770	200	410	380	6
906	1400	350	950	225	410	380	6
907	1200	420	900	150	510	470	6
034	1700	450	1100	300	590	540	7
039	2150	570	1600	275	710	660	7
041	1350	420	900	225	560	510	7
042	1800	500	1400	200	640	590	7

TMA Series

Multistage Centrifugal Pumps



Pompa tipo Pump model	DIMENSIONI Dimensions			Electric Motor															
				90L				100L				112M				132S			
	DNA	DNM	B	N°	M	H	Peso Weight	N°	M	H	Peso Weight	N°	M	H	Peso Weight	N°	M	H	Peso Weight
TMA 31-3 & 32-3	40	32	125	901	70	220	62	901	100	220	62	901	100	220	62	900	30	225	62
TMA 31-4 & 32-4	40	32	164					901	115	220	67					900	50	225	73
TMA 31-5 & 32-5	40	32	203									901	130	220	72	900	70	225	78
TMA 31-6 & 32-6	40	32	242									900	55	225	82	900	90	225	83
TMA 31-7 & 32-7	40	32	281													900	110	225	88
TMA 31-8 & 32-8	40	32	320													900	135	225	93
TMA 31-9 & 32-9	40	32	359													900	135	225	98
TMA 31-10 & 32-10	40	32	398													903	80	222	119
TMA 31-11 & 32-11	40	32	437																
TMA 31-12 & 32-12	40	32	476																
TMA 31-13 & 32-13	40	32	515																
TMA 31-14 & 32-14	40	32	554																
TMA 31-15 & 32-15	40	32	593																
TMA 40-3 & 50-3	65	50	171													900	100	225	125
TMA 40-4 & 50-4	65	50	217													900	120	225	132
TMA 40-5 & 50-5	65	50	263													900	140	225	139
TMA 40-6 & 50-6	65	50	309																
TMA 40-7 & 50-7	65	50	355																
TMA 40-8 & 50-8	65	50	401																
TMA 40-9 & 50-9	65	50	447																
TMA 40-10 & 50-10	65	50	493																
TMA 40-11 & 50-11	65	50	539																
TMA 40-12 & 50-12	65	50	585																
TMA 40-13	65	50	631																
TMA 40-14	65	50	677																
TMA 40-15	65	50	723																

Pompa tipo Pump model	DIMENSIONI Dimensions			Electric Motor																							
				160M / 160L				180M				200L				225M				250M				280S			
	DNA	DNM	B	N°	M	H	Peso Weight	N°	M	H	Peso Weight	N°	M	H	Peso Weight	N°	M	H	Peso Weight	N°	M	H	Peso Weight	N°	M	H	Peso Weight
TMA 31-3 & 32-3	40	32	125																								
TMA 31-4 & 32-4	40	32	164																								
TMA 31-5 & 32-5	40	32	203																								
TMA 31-6 & 32-6	40	32	242	903	60	250	102																				
TMA 31-7 & 32-7	40	32	281	903	80	250	107																				
TMA 31-8 & 32-8	40	32	320	903	100	250	112																				
TMA 31-9 & 32-9	40	32	359	903	120	250	117																				
TMA 31-10 & 32-10	40	32	398	906	70	260	146																				
TMA 31-11 & 32-11	40	32	437	906	90	260	150																				
TMA 31-12 & 32-12	40	32	476	906	110	260	155	041	150	310	178																
TMA 31-13 & 32-13	40	32	515	906	130	260	159	034	60	310	201																
TMA 31-14 & 32-14	40	32	554	906	145	260	164	034	90	310	205	034	100	330	221												
TMA 31-15 & 32-15	40	32	593	906	160	260	169	034	125	310	210	034	125	330	225												
TMA 40-3 & 50-3	65	50	171	903	60	250	139	907	25	280	155	907	50	300	162												
TMA 40-4 & 50-4	65	50	217	903	85	250	146	907	50	280	162	907	75	300	169												
TMA 40-5 & 50-5	65	50	263	903	110	250	153	907	75	280	169	907	100	300	176	034	0	355	221								
TMA 40-6 & 50-6	65	50	309	903	135	250	160	907	95	280	176	907	110	300	183	034	0	355	228	042	0	380	253				
TMA 40-7 & 50-7	65	50	355	903	155	250	167	907	110	280	183	041	135	330	218	034	0	355	235	042	0	380	260				
TMA 40-8 & 50-8	65	50	401	907	110	260	185	041	135	310	218	041	155	330	225	034	0	355	242	042	0	380	267	039	0	410	264
TMA 40-9 & 50-9	65	50	447	906	110	260	191	041	155	310	225	041	180	330	232	034	25	355	249	042	0	380	274	039	0	410	271
TMA 40-10 & 50-10	65	50	493	906	135	260	198	041	180	310	232	034	60	330	251	034	60	355	256	042	20	380	281	039	0	410	278
TMA 40-11 & 50-11	65	50	539					034	100	310	251	034	100	330	258	034	100	355	263	042	40	380	288	039	0	410	285
TMA 40-12 & 50-12	65	50	585					034	150	310	258	034	150	330	265	034	150	355	270	042	80	380	295	039	0	410	292
TMA 40-13	65	50	631					034	200	310	265	034	200	330	272	034	200	355	277	042	130	380	302	039	0	410	299
TMA 40-14	65	50	677									034	230	330	279	034	230	355	284	042	150	380	309	039	30	410	306
TMA 40-15	65	50	723									034	230	330	286	034	230	355	291	042	150	380	316	039	70	410	313

Construction R is available up to versions TMA 31-9 and 32-9, construction C is available up to versions TMA 31-15 and 32-15.

Schematic drawing. Dimensions in mm with tolerance to EN 735-1995 standards. Weights in kgs, referred to pump in cast iron "F" construction without motor, not binding.

TMA Series

Multistage Centrifugal Pumps

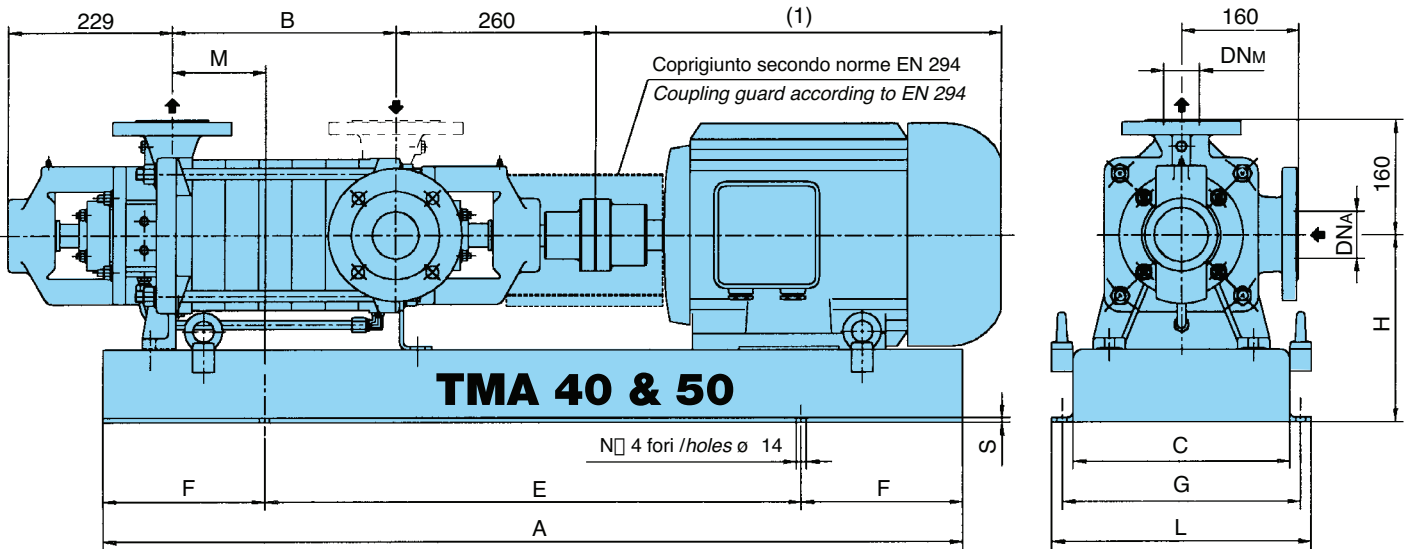

DIMENSIONI FLANGE FLANGES DIMENSIONS

DNA - DNm	D	K	P	N. Fori Holes
32	140	100	18	4
40	150	110	18	4
50	165	125	18	4
65	185	145	18	4

FLANGES:

Flanges ND32 and ND50 dimensions
to UNI 2223-2229 NP40 standards
Flanges ND40 and ND65 dimensions
to UNI 2223-2229 NP16 standards

ELECTRIC MOTOR

Grandezza Frame size IEC	Giri/min. RPM 2900 kW
90 L	2,2
100 L	3
112 M	4
132 S	5,5 - 7,5
160 M	11 - 15
160 L	18,5
180 M	22
200 L	30 - 37
225 M	45
250 M	55
280 S	75

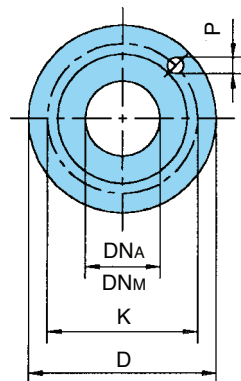

(1) Not binding dimensions according to installed motor supplier.

TMA Series

Multistage Centrifugal Pumps



TECHNICAL INFORMATION

Diagram of saturated vapour pressure and water density with temperature from 80 to 200°C

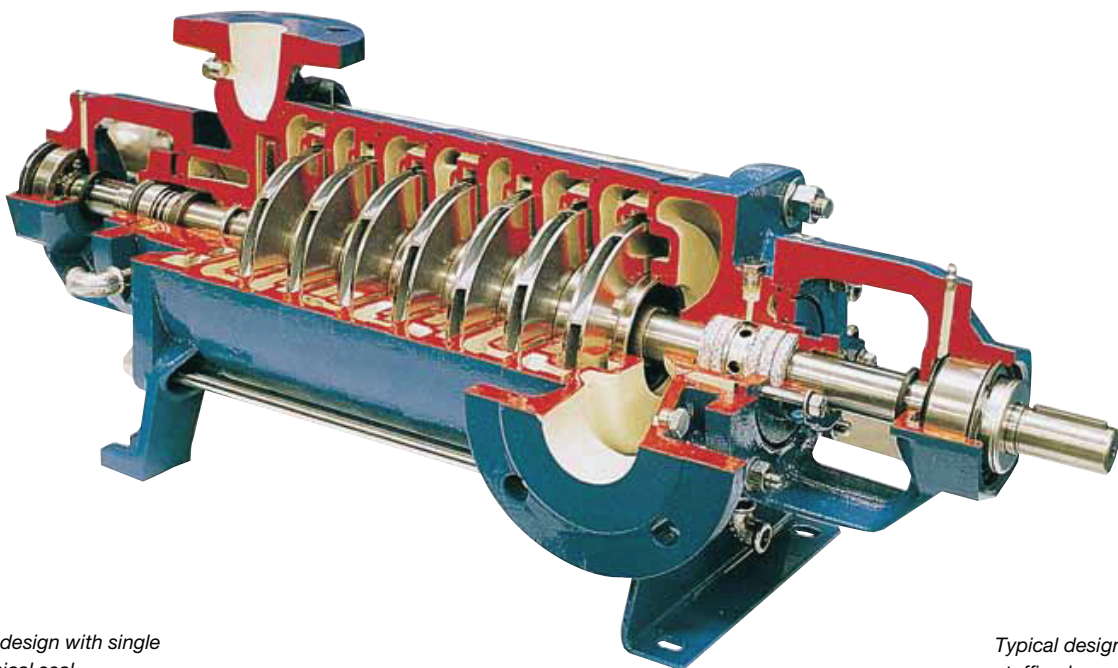
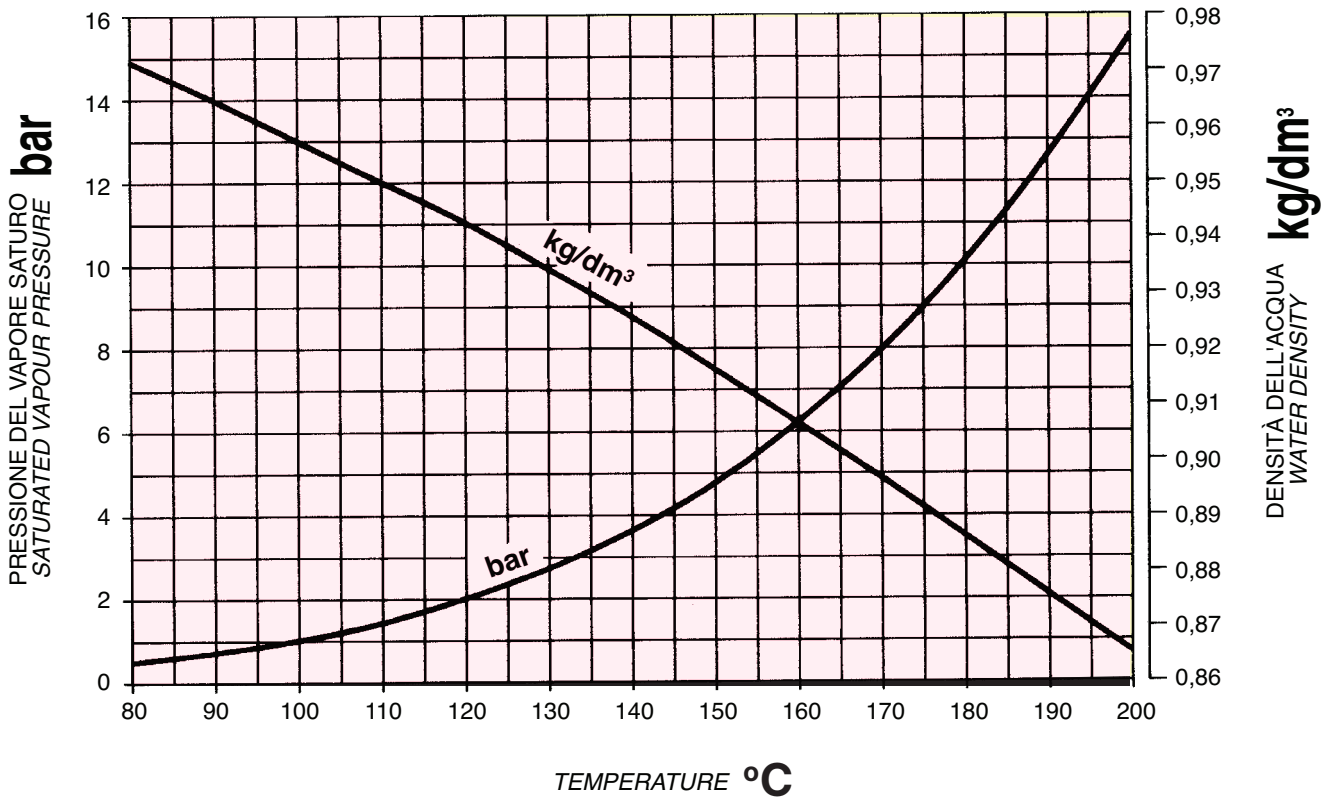

Typical design with single mechanical seal

Typical design with stuffing box

TMA Series

Multistage Centrifugal Pumps



CONSTRUCTION EXAMPLES

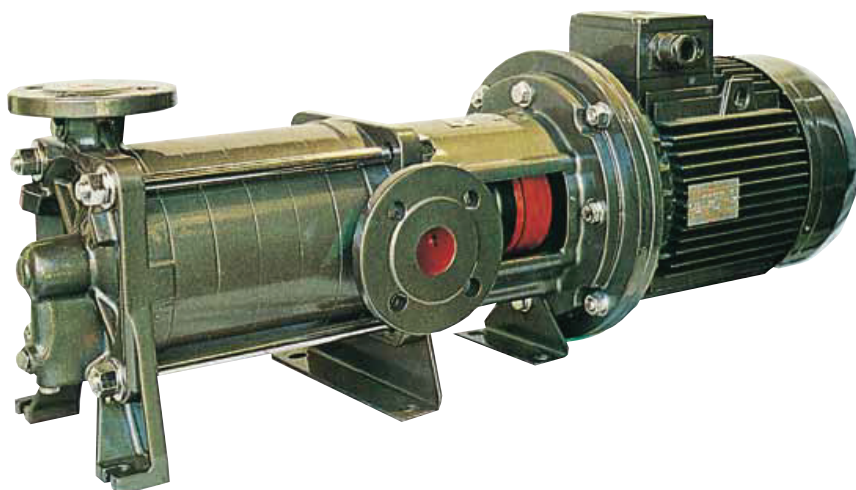

Pompa serie TMA 31 e 32 - Esecuzione Monoblocco con motore B5
Pump series TMA 31 and 32 - Close coupled construction with B5 motor



Pompa serie TMA 31 e 32 - Esecuzione Verticale con motore B5
Pump series TMA 31 and 32 - Vertical construction with B5 motor

Pompa serie TMA 40 e 50 - Esecuzione Accoppiata su basamento con motore a scoppio
Pump series TMA 40 and 50 - Base mounted construction with internal combustion engine

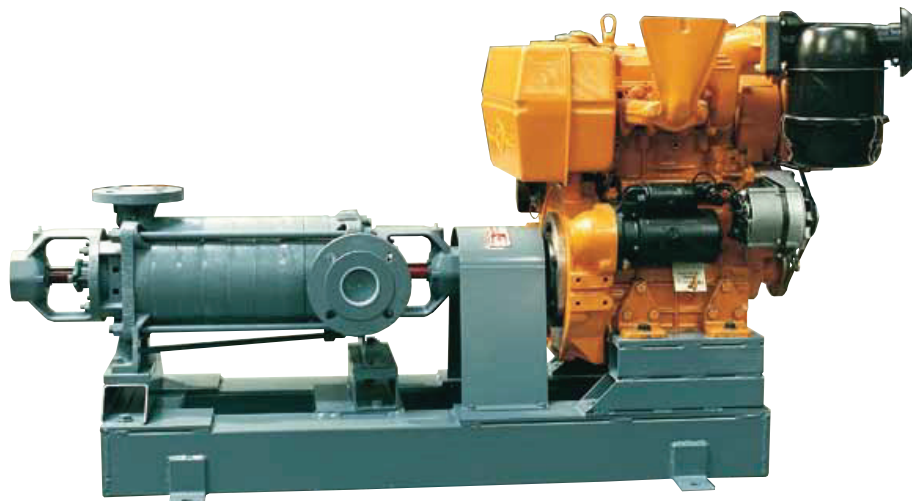

Available in New Zealand from:

Prime Fluid Management

Head Office: 10 Chesterfield St

Greymouth, West Coast

0800 482 747

primefluid.co.nz

